

FICHA TÉCNICA

**Dunham-Bush
WCFX E R134A**



PHYSICAL SPECIFICATIONS

Model	WCFX-E	10S	12S	15S	19S*	20S*	20T*	22T*	23S*	24S*	24T*
Cooling Capacity	TR	71.1	89.1	108.1	133.0	164.1	142.3	160.3	186.5	202.1	177.6
	kW	250.1	313.4	380.2	467.8	577.1	500.5	563.8	655.9	710.8	624.6
	10 ⁴ kcal/h	21.5	26.9	32.7	40.2	49.6	43.0	48.5	56.4	61.1	53.7
Min % Unit Capacity		25%	25%	25%	25%	25%	12.5%	12.5%	25%	25%	12.5%
Power		460/3P/60Hz									
Compressor											
Model (Qty)		1210(1)	1212(1)	1215(1)	1210(1)	1222(1)	1210(2)	1210(1)/1212(1)	1222(1)	1227(1)	1212 (2)
Power Input	kW	44	53	63	77	96	89.3	97.5	105	115	108
RLA, Each		78	104	129	126	154	78.0(2)	78.0/104.0	154	193	104.0(2)
LRA, Each		425	588	644	612	749	424.5(2)	424.5/588.0	749	923	588.0(2)
Evaporator											
Model		C3R	D2R	E2R	FAR	EAR	EAR	JAR	JAR	JBR	JBR
Connection Size	inches[mm]	5[127]	6[152]	6[152]	8[203]	6[152]	6[152]	8[203]	8[203]	8[203]	8[203]
Design Press. Water Side	psig[kPa]	150[1034]	150[1034]	150[1034]	150[1034]	150[1034]	150[1034]	150[1034]	150[1034]	150[1034]	150[1034]
Water Flow Rate	USgpm[m ³ /hr]	170.6[38.8]	213.8[48.6]	259.4[59.0]	320.0[72.7]	393.8[89.5]	342.8[77.9]	386.7[87.9]	447.6[101.7]	485.0[110.2]	427.6[97.2]
Evap. Pressure Drop	psig[kPa]	1.6[11.0]	1.7[11.7]	1.6[11.0]	2.0[13.8]	4.1[30.3]	3.3[22.8]	3.9[26.9]	4.2[28.9]	4.4[30.3]	3.7[25.5]
Condenser											
Model		B4R	B5R	C2R	D2R	5BR	5BR	5BR	5BR	5CR	5CR
Connection Size	inches[mm]	5[127]	5[127]	6[152]	6[152]	6[152]	6[152]	6[152]	6[152]	6[152]	6[152]
Design Press. Water Side	psig[kPa]	150[1034]	150[1034]	150[1034]	150[1034]	150[1034]	150[1034]	150[1034]	150[1034]	150[1034]	150[1034]
Water Flow Rate	USgpm[m ³ /hr]	213.3[48.5]	267.3[60.8]	324.3[73.7]	368.7[83.8]	492.3[111.9]	401.4[91.2]	457.8[104.0]	559.5[127.1]	606.3[137.8]	498.3[113.3]
Cond. Pressure Drop	psig[kPa]	2.0[13.8]	2.2[15.2]	2.3[15.8]	2.5[17.2]	4.0[27.5]	3.4[23.4]	4.3[29.6]	4.9[33.8]	4.4[30.3]	3.9[26.9]
Dimensions											
Length	inches[mm]	124 1/4 [3157]	124 1/4 [3157]	124 1/2 [3162]	132 3/16 [3358]	164 3/16 [4171]	152 3/16 [3866]	152 3/16 [3866]	164 3/16 [4171]	164 3/16 [4171]	152 3/16 [3866]
Width	inches[mm]	42 3/16 [1072]	45 3/16 [1148]	50 5/8 [1286]	70 [1778]	70 [1778]	52 3/8 [1330]	53 11/16 [1364]	70 [1778]	70 [1778]	53 11/16 [1364]
Height	inches[mm]	72 15/16 [1852]	72 15/16 [1852]	83 1/4 [2115]	71 1/4 [1810]	67 15/16 [1725]	78 7/8 [2003]	80 7/8 [2054]	70 3/16 [1783]	70 3/16 [1783]	80 7/8 [2054]
General Information											
Shipping Weight	lbs[kg]	4475[2030]	4696[2130]	5170[2345]	8576[3890]	10497[4761]	7981[3620]	8862[4020]	10915[4951]	11326[5137]	9669[4387]
Operating Weight	lbs[kg]	4805[2180]	4805[2180]	5622[2550]	9370[4250]	11173[5068]	8929[4050]	9700[4400]	11631[5276]	12118[5497]	10465[4747]
Approx. Refrig. Charge R134a	lbs[kg]	254[115]	320[145]	364[165]	419[190]	529[240]	529[240]	558[253]	558[253]	584[265]	584[265]

Model	WCFX-E	27S*	27T*	30S*	30T*	36S	38T*	40T*	41S	46T*	
Cooling Capacity	TR	220.8	197.0	248.6	213.5	292.4	270.5	330.4	332.2	375.5	
	kW	776.6	692.8	874.3	750.9	1028.4	951.3	1162.0	1168.3	1320.6	
	10 ⁴ kcal/h	66.8	59.6	75.2	64.6	88.4	81.8	99.9	100.5	113.6	
Min % Unit Capacity		25%	12.5%	25%	12.5%	25%	12.5%	12.5%	25%	12.5%	
Power		460/3P/60Hz									
Compressor											
Model (Qty)		1227(1)	1212(1)/1215(1)	1230(1)	1215(2)	2233(1)	1220(2)	1222(2)	2236(1)	1222(2)	
Power Input	kW	124	115.9	143	127.4	162	151.5	185.7	184	207	
RLA, Each		193	104.0/129.0	224	129.0(2)	259	126.0(2)	154.0(2)	309	154(2)	
LRA, Each		923	588.0/643.5	1019	643.5(2)	1380	612.4(2)	748.5(2)	1821	749(2)	
Evaporator											
Model		6DR	6DR	6ER	6ER	7CR	6CR	8BR	7BR	8DR	
Connection Size	inches[mm]	8[203]	8[203]	8[203]	8[203]	8[203]	8[203]	10[254]	10[254]	10[254]	
Design Press. Water Side	psig[kPa]	150[1034]	150[1034]	150[1034]	150[1034]	150[1034]	150[1034]	150[1034]	150[1034]	150[1034]	
Water Flow Rate	USgpm[m ³ /hr]	529.9[120.4]	474.0[107.7]	596.6[135.6]	513.6[116.7]	701.8[159.5]	655.2[148.9]	798.8[181.5]	797.3[181.2]	901.2[204.8]	
Evap. Press. Drop	psig[kPa]	3.8[26.2]	3.2[22.1]	4.3[29.3]	3.4[23.4]	4.6[31.7]	5.1[35.2]	4.7[32.4]	4.7[32.4]	5[34.5]	
Condenser											
Model		6CR	6CR	1KR	1KR	RAR	K5R	M3R	M1R	M5R	
Connection Size	inches[mm]	6[152]	6[152]	8[203]	8[203]	8[203]	8[203]	10[254]	10[254]	10[254]	
Design Press. Water Side	psig[kPa]	150[1034]	150[1034]	150[1034]	150[1034]	150[1034]	150[1034]	150[1034]	150[1034]	150[1034]	
Water Flow Rate	USgpm[m ³ /hr]	662.4[150.6]	547.0[124.3]	745.8[168.5]	596.4[135.5]	877.2[199.4]	749.4[170.3]	913.8[207.7]	996.6[226.5]	1126.5[256.0]	
Cond. Press. Drop	psig[kPa]	4.7[32.4]	4.1[28.3]	4.5[31.1]	3.7[25.5]	4.9[33.8]	5.2[35.9]	4.8[33.1]	4.7[32.4]	4.6[31.7]	
Dimensions											
Length	inches[mm]	164 3/16 [4171]	152 11/16 [3878]	164 3/16 [4171]	158 1/16 [4015]	174 3/16 [4425]	196 3/4 [4997]	196 3/4 [4997]	174 3/16 [4425]	196 3/4 [4997]	
Width	inches[mm]	70[1778]	55 1/2[1410]	70[1778]	55 9/16[1412]	70[1778]	75[1905]	80[2032]	70[1778]	80[2032]	
Height	inches[mm]	72 3/16 [1833]	87 3/8 [2219]	75 3/4 [1923]	87 3/8 [2219]	86 5/8 [2200]	78 [1981]	84 7/16 [2145]	86 5/8 [2200]	84 7/16 [2145]	
General Information											
Shipping Weight	lbs[kg]	11962[5426]	10306[4676]	13075[5931]	11419[5181]	15205[6897]	14103[6397]	17414[7899]	16180[7339]	18211[8261]	
Operating Weight	lbs[kg]	12833[5821]	11180[5071]	14052[6374]	12398[5624]	16473[7472]	15393[6982]	18673[8470]	17633[7998]	19863[9010]	
Approx. Refrig. Charge R134a	lbs[kg]	705[320]	705[320]	750[340]	750[340]	981[445]	882[400]	1014[460]	1102[500]	1113[505]	

*Optional compact footprint series is available. Unit height may be increased. Please consult factory for details.

- Notes: 1. This physical specifications table is based on Superior vessel models with the following operation condition: inlet/outlet cooled water temperature 54/44 °F, inlet/outlet cooling water temperature 85/95 °F, Fouling factor of evaporator 0.0001 hr.ft² °F/Btu, Fouling factor of condenser 0.00025 hr.ft² °F/Btu.
 2. Actual capacity will depend on the specified conditions. To consult nearest Dunham-bush sales office for computer selections.
 3. Non-standard chillers can be designed according to different requirements.



PHYSICAL SPECIFICATIONS

Model	WCFX-E	50T	54T	57T	60T	69	73	73T	75T	77
Cooling Capacity	TR	410	445	474.8	504.2	564	600.8	582.4	622.2	634.4
	kW	1442.0	1565.1	1669.9	1773.3	1983.6	2113.0	2048.3	2188.3	2231.2
	10 ⁴ kcal/h	124.0	134.6	143.6	152.5	170.6	181.7	176.2	188.2	191.9
Min % Unit Capacity		12.5%	12.5%	12.5%	12.5%	8.5%	8.5%	12.5%	12.5%	8.5%
Power		460/3P/60Hz								
Compressor										
Model (Qty)		1227(1)/ 1222(1)	1227(2)	1230(1)/ 1227(1)	1230(2)	1222(3)	1227(1)/ 1222(2)	2233(2)	2236(1)/ 2233(1)	1227(2)/ 1222(1)
Power Input	kW	226	245	263	281	320	338	327	349	358
RLA, Each		193/ 154	193(2)	224/ 193	224(2)	154(3)	193/ 154(2)	259(2)	309/ 259	193(2)/ 154
LRA, Each		923/ 749	923(2)	1019/ 923	1019(2)	749(3)	923/ 749(2)	1380(2)	1821/ 1380	923(2)/ 749
Evaporator										
Model		KBR	YAR	YBR	YCR	CGR	DBR	MAR	MBR	DCR
Connection Size	inches[mm]	10[254]	10[254]	10[254]	10[254]	10[254]	12[305]	12[305]	12[305]	12[305]
Design Press. Water Side	psig[kPa]	150[1034]	150[1034]	150[1034]	150[1034]	150[1034]	150[1034]	150[1034]	150[1034]	150[1034]
Water Flow Rate	USgpm[m ³ /hr]	984.0[223.6]	1068.0[242.7]	1139.5[259.0]	1210.1[275.0]	1353.6[307.6]	1441.9[327.7]	1397.8[317.7]	1493.3[339.4]	1522.6[346.0]
Evap. Press. Drop	psig[kPa]	4.9[33.8]	4.9[33.8]	5.1[35.1]	5.2[35.8]	6.3[43.4]	5.9[40.7]	5.6[38.6]	5.7[39.3]	6.0[41.34]
Condenser										
Model		T5R	YAR	YBR	YCR	1BR	1CR	JAR	JBR	1CR
Connection Size	inches[mm]	10[254]	10[254]	10[254]	10[254]	10[254]	10[254]	12[305]	12[305]	10[254]
Design Press. Water Side	psig[kPa]	150[1034]	150[1034]	150[1034]	150[1034]	150[1034]	150[1034]	150[1034]	150[1034]	150[1034]
Water Flow Rate	USgpm[m ³ /hr]	1230.0[279.7]	1335.0[303.4]	1424.4[323.7]	1512.6[343.8]	1692.0[384.6]	1802.4[409.6]	1747.2[397.1]	1866.6[424.2]	1903.2[432.5]
Cond. Press. Drop	psig[kPa]	4.9[33.8]	4.8[33.1]	4.9[33.8]	5[34.5]	5.5[37.9]	5.5[37.9]	5.8[40.0]	5.3[36.5]	5.7[39.3]
Dimensions										
Length	inches[mm]	196 3/4 [4997]	196 3/4 [4997]	196 3/4 [4997]	196 3/4 [4997]	213 3/4 [5429]	213 3/4 [5429]	206 3/4 [5251]	206 3/4 [5251]	213 3/4 [5429]
Width	inches[mm]	80[2032]	80[2032]	80[2032]	80[2032]	88[2235]	88[2235]	88[2235]	88[2235]	88[2235]
Height	inches[mm]	86 7/16 [2196]	86 11/16 [2202]	86 11/16 [2202]	86 11/16 [2202]	86 [2184]	86 [2184]	82 7/8 [2104]	82 7/8 [2104]	86 [2184]
General Information										
Shipping Weight	lbs[kg]	19928[9039]	21645[9818]	22456[10186]	23071[10465]	26280[11920]	29203[13246]	26820[12165]	27597[12518]	29665[13456]
Operating Weight	lbs[kg]	21688[9837]	23588[10699]	24486[11107]	25208[11434]	28807[13067]	31949[14492]	29144[13220]	30111[13686]	32458[14723]
Approx. Refrig. Charge R134a	lbs[kg]	1312[595]	1356[615]	1422[645]	1477[670]	1731[785]	1940[880]	1455[660]	1543[700]	2017[915]

Model	WCFX-E	81	81T	84	87	90	108	113	118	123
Cooling Capacity	TR	668.1	665.3	697.3	726.1	753.7	875.8	916.6	953.7	998.2
	kW	2381.0	2339.9	2452.0	2553.7	2650.8	3080.2	3223.7	3354.2	3510.7
	10 ⁴ kcal/h	204.8	201.2	210.9	219.6	228.0	264.9	277.2	288.5	301.9
Min % Unit Capacity		8.5%	12.5%	8.5%	8.5%	8.5%	8.5%	8.5%	8.5%	8.5%
Power		460/3P/60Hz								
Compressor										
Model (Qty)		1227(3)	2236(2)	1230(1)/ 1227(2)	1230(2)/ 1227(1)	1230(3)	2233(3)	2236(1)/ 2233(2)	2236(2)/ 2233(1)	2236(3)
Power Input	kW	377	369	394	411	429	494	517	539	558
RLA, Each		193(3)	309(2)	224/ 193(2)	224(2)/ 193	224(3)	259(3)	309/ 259(2)	309(2)/ 259	309(3)
LRA, Each		923(3)	1821(2)	1019/ 923(2)	1019(2)/ 923	1019(3)	1380(3)	1821/ 1380(2)	1821(2)/ 1380	1821(3)
Evaporator										
Model		N1R	NAR	PCR	PAR	PAR	SCR	SDR	TAR	TBR
Connection Size	inches[mm]	12[305]	12[305]	12[305]	12[305]	12[305]	14[356]	14[356]	14[356]	14[356]
Design Press. Water Side	psig[kPa]	150[1034]	150[1034]	150[1034]	150[1034]	150[1034]	150[1034]	150[1034]	150[1034]	150[1034]
Water Flow Rate	USgpm[m ³ /hr]	1603.2[364.4]	1596.7[362.9]	1672.6[380.1]	1742.6[396.1]	1808.9[411.1]	2101.9[477.7]	2199.8[500.0]	2288.9[520.2]	2395.7[544.5]
Evap. Press. Drop	psig[kPa]	6.1[42.0]	5.2[35.8]	5.5[37.9]	5.6[38.6]	6.2[42.7]	5.7[39.3]	5.8[40.0]	6.1[42.0]	5.1[35.1]
Condenser										
Model		7BR	KAR	7BR	7CR	8AR	9AR	9BR	WAR	WBR
Connection Size	inches[mm]	12[305]	12[305]	12[305]	12[305]	12[305]	14[356]	14[356]	14[356]	14[356]
Design Press. Water Side	psig[kPa]	150[1034]	150[1034]	150[1034]	150[1034]	150[1034]	150[1034]	150[1034]	150[1034]	150[1034]
Water Flow Rate	USgpm[m ³ /hr]	2004.0[455.5]	1995.9[453.6]	2090.7[475.2]	2178.3[495.1]	2261.1[513.9]	2627.4[597.1]	2749.8[625.0]	2861.1[650.3]	2994.6[680.6]
Cond. Press. Drop	psig[kPa]	5.2[35.8]	4.9[33.8]	5.6[38.6]	5.7[39.3]	5.6[38.6]	5.2[35.8]	5.0[34.5]	4.5[31.0]	4.3[29.6]
Dimensions										
Length	inches[mm]	213 3/4 [5429]	206 3/4 [5251]	213 3/4 [5429]	213 3/4 [5429]	213 3/4 [5429]	201 3/4 [5124]	201 3/4 [5124]	199 [5055]	199 [5055]
Width	inches[mm]	88[2235]	88[2235]	88[2235]	88[2235]	88[2235]	99[2515]	99[2515]	99[2515]	99[2515]
Height	inches[mm]	86 [2184]	86 7/8 [2206]	86 7/8 [2206]	86 7/8 [2206]	91 1/4 [2318]	127 15/16 [3249]	127 15/16 [3249]	129 9/16 [3291]	129 9/16 [3291]
General Information										
Shipping Weight	lbs[kg]	31856[14450]	29952[13586]	33704[15288]	34339[15576]	35538[16120]	41832[18975]	43084[19543]	47673[21624]	49160[22298]
Operating Weight	lbs[kg]	34889[15825]	32773[14866]	36873[16725]	37608[17059]	38920[17954]	44342[20113]	45669[20715]	50533[22921]	52109[23636]
Approx. Refrig. Charge R134a	lbs[kg]	2260[1025]	1808[820]	2635[1195]	2701[1225]	2701[1225]	2253[1022]	2392[1085]	2601[1180]	2833[1285]

Notes: 1. This physical specifications table is based on Superior vessel models with the following operation condition: inlet/outlet cooled water temperature 54/44 °F, inlet/outlet cooling water temperature 85/95 °F, Fouling factor of evaporator 0.0001 hr.ft.².°F/Btu, Fouling factor of condenser 0.00025 hr.ft.².°F/Btu.
 2. Actual capacity will depend on the specified conditions. To consult nearest Dunham-bush sales office for computer selections.
 3. Non-standard chillers can be designed according to different requirements.

DIMENSIONAL DATA

WCFX-E 10S, 12S, 15S

MODEL	A	B	C	D	E	F	G	HEIGHT	I	J	K	LENGTH	M	WIDTH	Y (Ø)	Z (Ø)
WCFX-E 10S	2 1/16 [53]	16 11/16 [424]	101 7/8 [2588]	6 [153]	2 1/2 [63]	10 1/16 [256]	5 1/8 [130]	72 15/16 [1852]	22 13/16 [580]	14 3/4 [374]	14 7/16 [366]	124 1/4 [3157]	4 [102]	42 3/16 [1072]	5 [127]	5 [127]
WCFX-E 12S	2 1/16 [53]	16 11/16 [424]	101 7/8 [2588]	6 [153]	1 7/16 [37]	11 1/8 [282]	5 5/8 [143]	72 15/16 [1852]	24 13/16 [630]	16 7/16 [417]	14 7/16 [366]	124 1/4 [3157]	4 [102]	45 3/16 [1148]	5 [127]	6 [152]
WCFX-E 15S	2 1/16 [53]	16 7/8 [429]	101 7/8 [2588]	6 [153]	1 9/16 [39]	12 3/8 [315]	5 5/8 [143]	83 1/4 [2115]	28 1/8 [715]	18 3/16 [462]	15 3/8 [391]	124 1/2 [3162]	4 1/2 [115]	50 5/8 [1286]	6 [152]	6 [152]

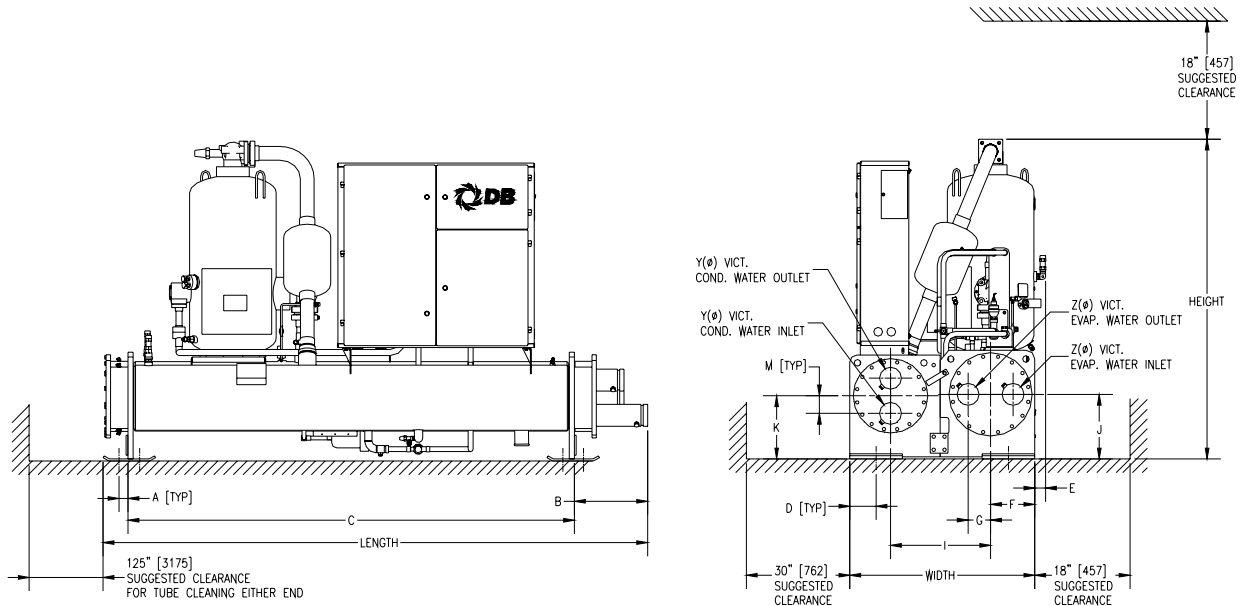

WCFX-E 19S*

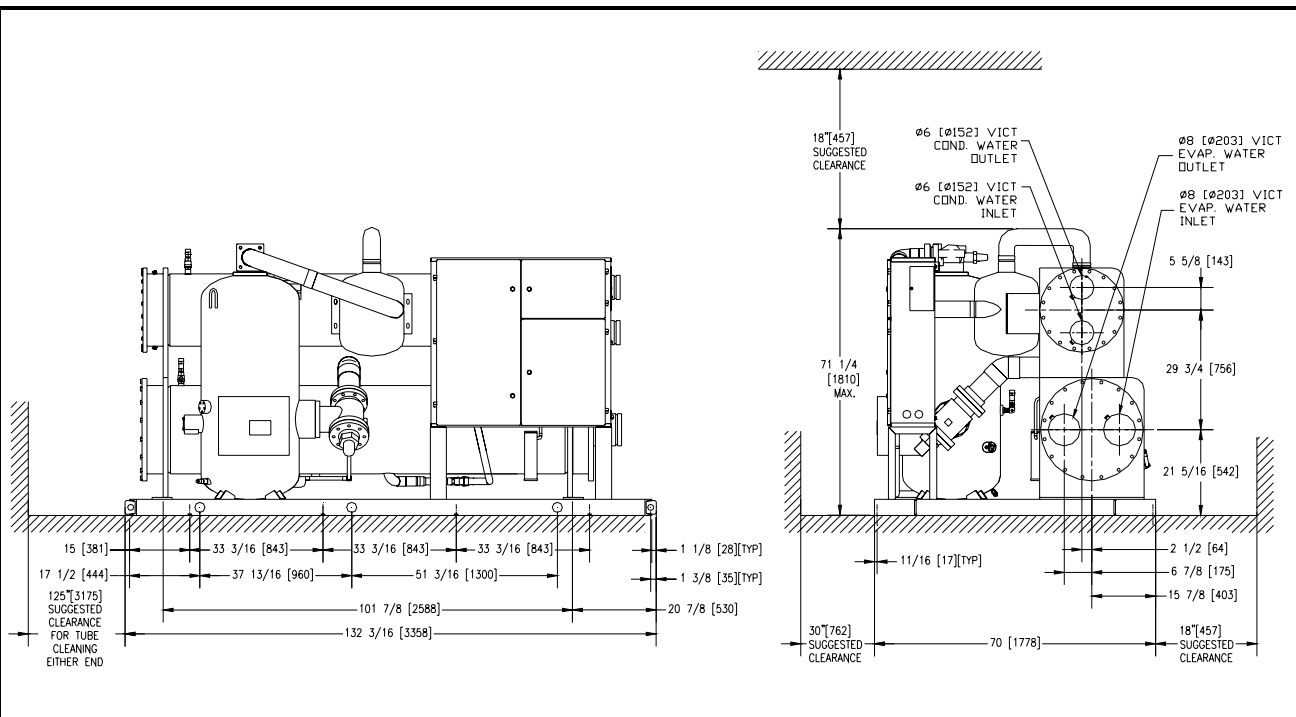

*Optional compact footprint series is available. Unit height may be increased. Please consult factory for details.

Notes : 1.) All dimensions are in inches[mm].

2.) Above drawing is for Superior model. Consult factory for Standard and Premium model dimension.

DIMENSIONAL DATA

WCFX-E 20S*, 23S*, 24S*, 27S*, 30S*, 36S, 41S

MODEL	A	B	C	D	E	F	G	HEIGHT	I	J	K	LENGTH	M	N	O	P	Q	R	S	WIDTH	Y (Ø)	Z (Ø)
WCFX-E 20S*	20 [508]	40 11/16 [1033]	40 11/16 [1033]	40 11/16 [1033]	25 [635]	58 1/2 [1486]	53 1/2 [1359]	67 15/16 [1725]	1 1/8 [28]	1 3/8 [35]	20 7/8 [530]	164 3/16 [4171]	11/16 [17]	1 3/8 [35]	5 5/8 [143]	15 7/8 [403]	20 5/16 [516]	28 1/2 [725]	5 5/8 [143]	70 [1778]	6 [152]	6 [152]
WCFX-E 23S*	20 [508]	40 11/16 [1033]	40 11/16 [1033]	40 11/16 [1033]	25 [635]	58 1/2 [1486]	53 1/2 [1359]	70 3/16 [1783]	1 1/8 [28]	1 3/8 [35]	20 7/8 [530]	164 3/16 [4171]	11/16 [17]	2 1/2 [64]	6 7/8 [175]	15 7/8 [403]	21 5/16 [542]	29 3/4 [756]	5 5/8 [143]	70 [1778]	6 [152]	8 [203]
WCFX-E 24S*	20 [508]	40 11/16 [1033]	40 11/16 [1033]	40 11/16 [1033]	25 [635]	58 1/2 [1486]	53 1/2 [1359]	70 3/16 [1783]	1 1/8 [28]	1 3/8 [35]	20 7/8 [530]	164 3/16 [4171]	11/16 [17]	2 1/2 [64]	6 7/8 [175]	15 7/8 [403]	21 5/16 [542]	29 3/4 [756]	5 5/8 [143]	70 [1778]	6 [152]	8 [203]
WCFX-E 27S*	20 [508]	40 11/16 [1033]	40 11/16 [1033]	40 11/16 [1033]	25 [635]	58 1/2 [1486]	53 1/2 [1359]	72 3/16 [1833]	1 1/8 [28]	1 3/8 [35]	20 7/8 [530]	164 3/16 [4171]	11/16 [17]	3 1/2 [89]	6 7/8 [175]	15 7/8 [403]	22 5/16 [567]	30 3/4 [782]	5 5/8 [143]	70 [1778]	6 [152]	8 [203]
WCFX-E 30S*	20 [508]	40 11/16 [1033]	40 11/16 [1033]	40 11/16 [1033]	25 [635]	58 1/2 [1486]	53 1/2 [1359]	75 3/4 [1923]	1 1/8 [28]	1 3/8 [35]	21 1/8 [536]	164 3/16 [4171]	11/16 [17]	2 1/4 [62]	6 7/8 [175]	15 7/8 [403]	22 5/16 [567]	31 3/4 [807]	6 1/16 [155]	70 [1778]	8 [203]	8 [203]
WCFX-E 36S	20 [508]	40 11/16 [1033]	40 11/16 [1033]	50 11/16 [1287]	30 11/16 [780]	60 [1524]	60 [1524]	86 5/8 [2200]	1 1/8 [28]	1 3/8 [35]	21 1/8 [536]	174 3/16 [4425]	11/16 [17]	2 [51]	8 1/8 [207]	15 7/8 [403]	23 5/16 [592]	33 3/4 [858]	6 7/8 [175]	70 [1778]	8 [203]	8 [203]
WCFX-E 41S	20 [508]	40 11/16 [1033]	40 11/16 [1033]	50 11/16 [1287]	30 11/16 [780]	60 [1524]	60 [1524]	86 5/8 [2200]	1 1/8 [28]	1 3/8 [35]	21 1/8 [536]	174 3/16 [4425]	11/16 [17]	1 [25]	7 3/8 [187]	15 7/8 [403]	23 5/16 [592]	34 3/4 [883]	6 7/8 [175]	70 [1778]	10 [254]	10 [254]

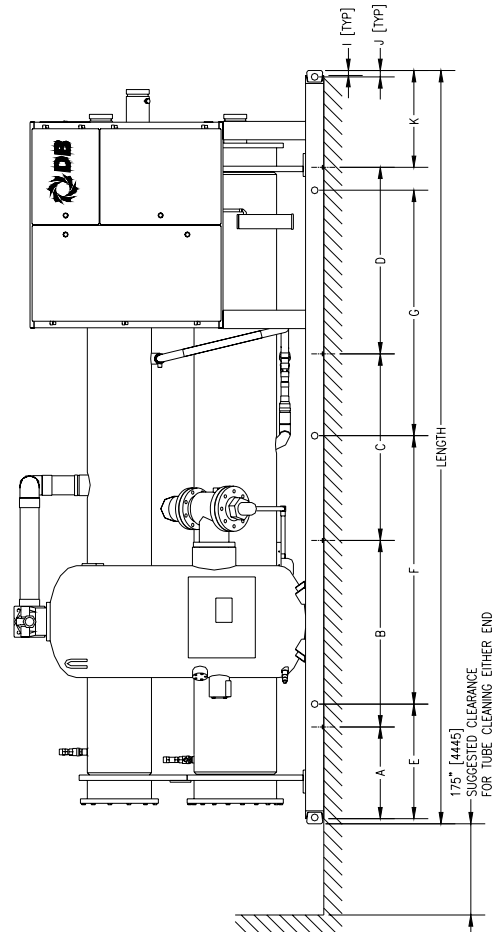
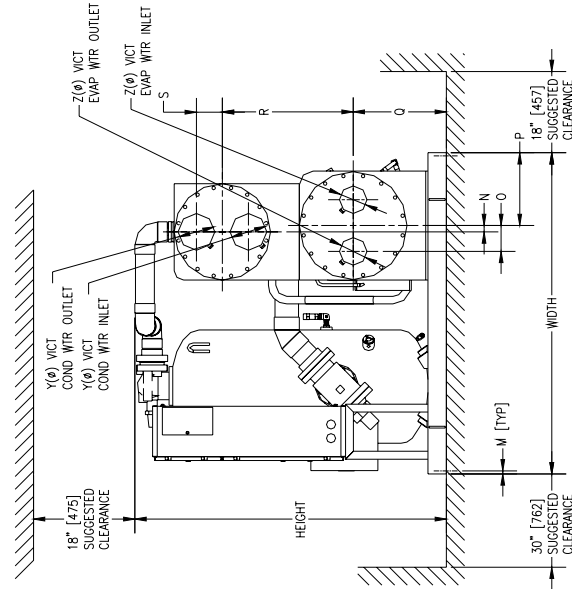

*Optional compact footprint series is available. Unit height may be increased. Please consult factory for details.
 Notes : 1.) All dimensions are in inches[mm].
 2.) Above drawing is for Superior model. Consult factory for Standard and Premium model dimension.

DIMENSIONAL DATA

WCFX-E 20T*, 22T*, 24T*, 27T*, 30T*

MODEL	A	B	C	D	E	F	G	HEIGHT	I	J	K	LENGTH	M	WIDTH	Y (Ø)	Z (Ø)
WCFX-E 20T*	2 [51]	12.5/8 [321]	134 [3404]	6 [153]	1.5/8 [41]	12.1/8 [303]	5.5/8 [143]	78 7/8 [2003]	27 3/8 [695]	18 3/16 [462]	15 1/4 [387]	152 3/16 [3866]	5.5/8 [143]	52 3/8 [1330]	6 [152]	6 [152]
WCFX-E 22T*	2 [51]	12.5/8 [321]	134 [3404]	6 [153]	1.7/8 [48]	13.1/8 [333]	6.7/8 [175]	80 7/8 [2054]	29 1/4 [743]	19 3/16 [487]	15 1/4 [387]	152 3/16 [3866]	5.5/8 [143]	55 11/16 [1414]	6 [152]	8 [203]
WCFX-E 24T*	2 [51]	12.5/8 [321]	134 [3404]	6 [153]	1.7/8 [48]	13.1/8 [333]	6.7/8 [175]	80 7/8 [2054]	29 1/4 [743]	19 3/16 [487]	15 1/4 [387]	152 3/16 [3866]	5.5/8 [143]	55 11/16 [1414]	6 [152]	8 [203]
WCFX-E 27T*	2 [51]	12.7/8 [327]	134 [3404]	6 [153]	1.7/8 [48]	14.1/2 [368]	6.7/8 [175]	87 3/8 [2219]	29 [737]	20 3/16 [513]	15 1/4 [387]	152 11/16 [4015]	5.5/8 [143]	56 [1422]	6 [152]	8 [203]
WCFX-E 30T*	2 [51]	18.1/4 [464]	134 [3404]	6 [153]	1.7/8 [48]	14.1/2 [368]	6.7/8 [175]	87 3/8 [2219]	28 13/16 [732]	20 3/16 [513]	16.1/4 [413]	158 1/16 [4015]	6.1/16 [155]	57 9/16 [1462]	8 [203]	8 [203]

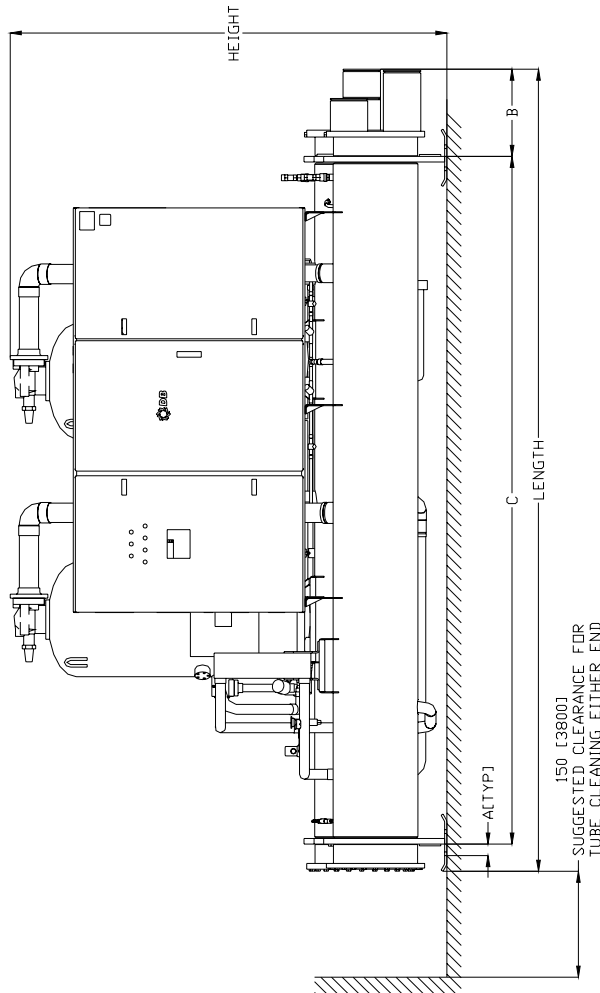
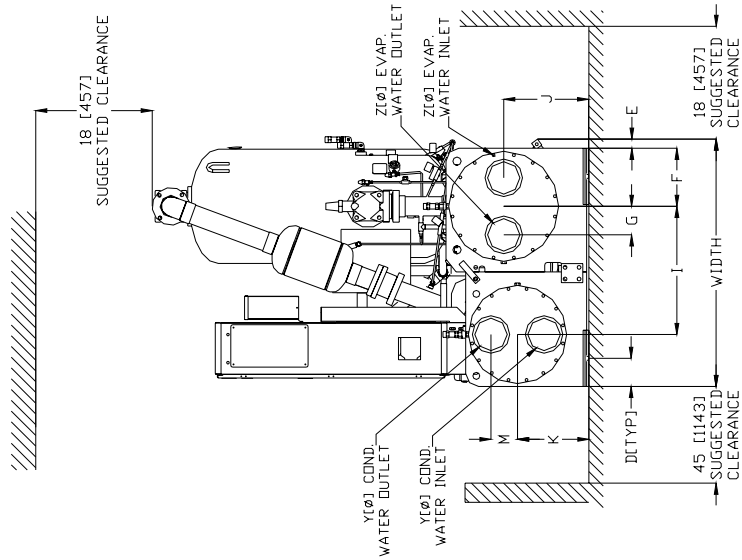

*Optional compact footprint series is available. Unit height may be increased. Please consult factory for details.

Notes : 1.) All dimensions are in inches[mm].

2.) Above drawing is for Superior model. Consult factory for Standard and Premium model dimension.

DIMENSIONAL DATA

WCFX-E 38T*, 40T*, 46T*, 50T, 54T, 57T, 60T, 73T, 75T, 81T

MODEL	A	B	C	D	E	F	G	HEIGHT	I	J	K	LENGTH	M	N	O	P	Q	R	S	WIDTH	Y (Ø)	Z (Ø)
WCFX-E 38T*	15 [381]	60 [1524]	60 [1524]	45 [1143]	24 [610]	68 1/2 [1740]	78 1/2 [1994]	78 [1981]	7/8 [22]	1 7/8 [48]	21 1/8 [537]	196 3/4 [4997]	1 1/2 [38]	2 1/4 [57]	6 7/8 [175]	17 1/2 [445]	24 3/16 [614]	31 3/4 [807]	6 1/16 [155]	75 [1905]	8 [203]	8 [203]
WCFX-E 40T*	15 [381]	60 [1524]	60 [1524]	45 [1143]	24 [610]	68 1/2 [1740]	78 1/2 [1994]	84 7/16 [2145]	7/8 [22]	1 7/8 [48]	21 1/8 [537]	196 3/4 [4997]	1 1/2 [38]	2 [51]	8 1/8 [207]	20 [508]	26 5/16 [669]	35 3/4 [909]	6 7/8 [175]	80 [2032]	10 [254]	10 [254]
WCFX-E 46T*	15 [381]	55 [1397]	55 [1397]	55 [1397]	26 [660]	64 1/2 [1638]	64 1/2 [1638]	81 [2057]	7/8 [22]	1 7/8 [48]	18 15/16 [480]	196 3/4 [4997]	1 1/2 [38]	2 [51]	8 1/8 [207]	20 [508]	26 5/16 [669]	35 3/4 [909]	6 7/8 [175]	80 [2032]	10 [254]	10 [254]
WCFX-E 50T	15 [381]	55 [1397]	55 [1397]	55 [1397]	26 [660]	64 1/2 [1638]	64 1/2 [1638]	86 7/16 [2196]	7/8 [22]	1 7/8 [48]	18 15/16 [480]	196 3/4 [4997]	1 1/2 [38]	3 [76]	8 5/8 [219]	20 [508]	27 5/16 [694]	36 3/4 [934]	6 7/8 [175]	80 [2032]	10 [254]	10 [254]
WCFX-E 54T	15 [381]	55 [1397]	55 [1397]	55 [1397]	26 [660]	64 1/2 [1638]	64 1/2 [1638]	96 11/16 [2402]	7/8 [22]	1 7/8 [48]	18 15/16 [480]	196 3/4 [4997]	1 1/2 [38]	3 7/8 [99]	8 5/8 [219]	20 [508]	28 5/16 [719]	39 11/16 [1008]	7 3/8 [187]	80 [2032]	10 [254]	10 [254]
WCFX-E 57T	15 [381]	55 [1397]	55 [1397]	55 [1397]	26 [660]	64 1/2 [1638]	64 1/2 [1638]	88 11/16 [2202]	7/8 [22]	1 7/8 [48]	18 15/16 [480]	196 3/4 [4997]	1 1/2 [38]	3 7/8 [99]	8 5/8 [219]	20 [508]	28 5/16 [719]	39 11/16 [1008]	7 3/8 [187]	80 [2032]	10 [254]	10 [254]
WCFX-E 60T	15 [381]	55 [1397]	55 [1397]	55 [1397]	26 [660]	64 1/2 [1638]	64 1/2 [1638]	86 11/16 [2202]	7/8 [22]	1 7/8 [48]	18 15/16 [480]	196 3/4 [4997]	1 1/2 [38]	3 7/8 [99]	8 5/8 [219]	20 [508]	28 5/16 [719]	39 11/16 [1008]	7 3/8 [187]	80 [2032]	10 [254]	10 [254]
WCFX-E 73T	15 [381]	53 11/16 [1363]	60 11/16 [1541]	60 11/16 [1541]	25 [635]	74 [1880]	81 [2057]	82 7/8 [2104]	7/8 [22]	1 7/8 [48]	20 5/8 [524]	206 3/4 [5251]	1 1/2 [38]	3 3/4 [95]	10 1/8 [258]	24 1/2 [622]	25 5/16 [643]	41 1/2 [1055]	8 [203]	88 [2235]	12 [305]	12 [305]
WCFX-E 75T	15 [381]	53 11/16 [1363]	60 11/16 [1541]	60 11/16 [1541]	25 [635]	74 [1880]	81 [2057]	82 7/8 [2104]	7/8 [22]	1 7/8 [48]	20 5/8 [524]	206 3/4 [5251]	1 1/2 [38]	3 3/4 [95]	10 1/8 [258]	24 1/2 [622]	25 5/16 [643]	41 1/2 [1055]	8 [203]	88 [2235]	12 [305]	12 [305]
WCFX-E 81T	15 [381]	53 11/16 [1363]	60 11/16 [1541]	60 11/16 [1541]	25 [635]	74 [1880]	81 [2057]	86 7/8 [2206]	7/8 [22]	1 7/8 [48]	20 5/8 [524]	206 3/4 [5251]	1 1/2 [38]	4 1/4 [108]	10 7/8 [258]	24 1/2 [622]	27 5/16 [694]	43 1/2 [1080]	8 1/8 [207]	88 [2235]	12 [305]	12 [305]

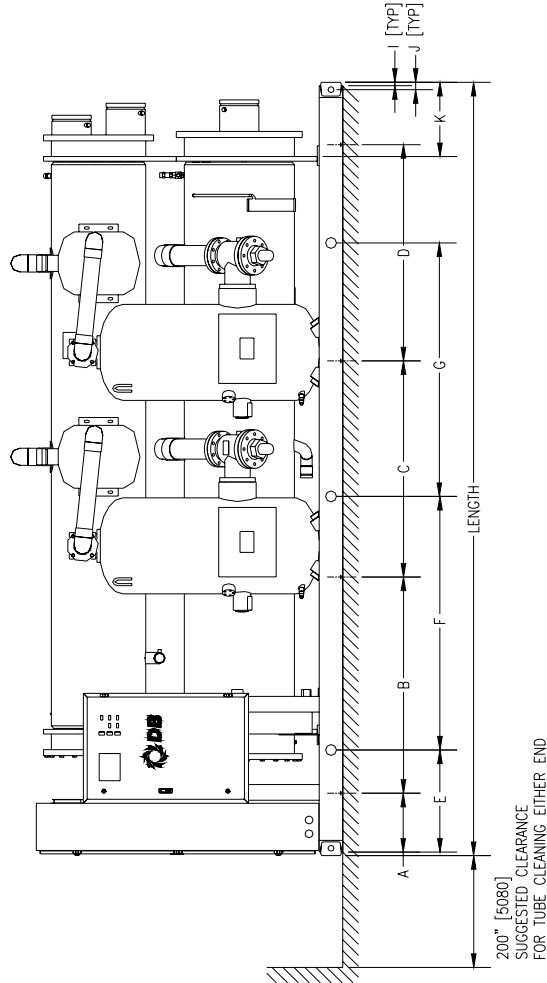
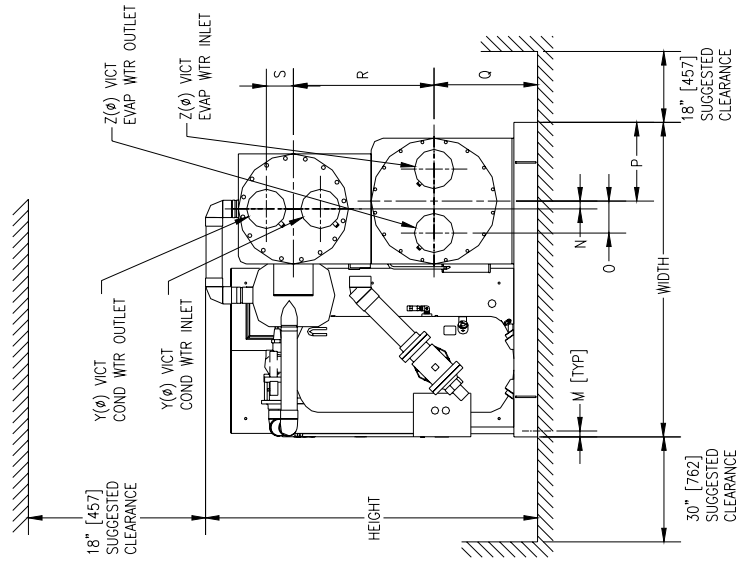

*Optional compact footprint series is available. Unit height may be increased. Please consult factory for details.

Notes : 1.) All dimensions are in inches[mm].

2.) Above drawing is for Superior model. Consult factory for Standard and Premium model dimension.

DIMENSIONAL DATA

WCFX-E 69, 73, 77, 81, 84, 87, 90

MODEL	A	B	C	D	E	F	G	HEIGHT	I	J	K	LENGTH	M	N	O	P	Q	R	S	WIDTH	Y (Ø)	Z (Ø)
WCFX-E 69	15 [381]	60 11/16 [1541]	60 11/16 [1541]	60 11/16 [1541]	25 [635]	81 [2057]	81 [2057]	86 [2184]	7/8 [22]	1 7/8 [48]	20 5/8 [524]	213 3/4 [5429]	1 1/2 [38]	2 7/8 [74]	8 5/8 [219]	25 1/2 [648]	24 5/16 [618]	40 11/16 [1033]	8 1/8 [207]	88 [2235]	10 [254]	10 [254]
WCFX-E 73	15 [381]	60 11/16 [1541]	60 11/16 [1541]	60 11/16 [1541]	25 [635]	81 [2057]	81 [2057]	86 [2184]	7/8 [22]	1 7/8 [48]	20 5/8 [524]	213 3/4 [5429]	1 1/2 [38]	3 3/4 [95]	10 1/8 [258]	25 1/2 [648]	24 5/16 [618]	41 1/2 [1055]	8 1/8 [207]	88 [2235]	10 [254]	12 [305]
WCFX-E 77	15 [381]	60 11/16 [1541]	60 11/16 [1541]	60 11/16 [1541]	25 [635]	81 [2057]	81 [2057]	86 [2184]	7/8 [22]	1 7/8 [48]	20 5/8 [524]	213 3/4 [5429]	1 1/2 [38]	3 3/4 [95]	10 1/8 [258]	25 1/2 [648]	24 5/16 [618]	41 1/2 [1055]	8 1/8 [207]	88 [2235]	10 [254]	12 [305]
WCFX-E 81	15 [381]	60 11/16 [1541]	60 11/16 [1541]	60 11/16 [1541]	25 [635]	81 [2057]	81 [2057]	86 [2184]	7/8 [22]	1 7/8 [48]	20 5/8 [524]	213 3/4 [5429]	1 1/2 [38]	4 1/4 [108]	10 3/16 [259]	25 1/2 [648]	27 5/16 [694]	41 1/2 [1055]	8 1/8 [207]	88 [2235]	12 [305]	12 [305]
WCFX-E 84	15 [381]	60 11/16 [1541]	60 11/16 [1541]	60 11/16 [1541]	25 [635]	81 [2057]	81 [2057]	86 7/8 [2206]	7/8 [22]	1 7/8 [48]	20 5/8 [524]	213 3/4 [5429]	1 1/2 [38]	5 1/4 [133]	10 3/16 [259]	25 1/2 [648]	27 5/16 [694]	42 1/2 [1080]	8 1/8 [207]	88 [2235]	12 [305]	12 [305]
WCFX-E 87	15 [381]	60 11/16 [1541]	60 11/16 [1541]	60 11/16 [1541]	25 [635]	81 [2057]	81 [2057]	86 7/8 [2206]	7/8 [22]	1 7/8 [48]	20 5/8 [524]	213 3/4 [5429]	1 1/2 [38]	5 1/4 [133]	10 3/16 [259]	25 1/2 [648]	27 5/16 [694]	42 1/2 [1080]	8 1/8 [207]	88 [2235]	12 [305]	12 [305]
WCFX-E 90	15 [381]	60 11/16 [1541]	60 11/16 [1541]	60 11/16 [1541]	25 [635]	81 [2057]	81 [2057]	91 1/4 [2318]	7/8 [22]	1 7/8 [48]	20 5/8 [524]	213 3/4 [5429]	1 1/2 [38]	3 3/8 [85]	10 3/16 [259]	25 1/2 [648]	27 5/16 [694]	45 [1144]	8 7/8 [226]	88 [2235]	12 [305]	12 [305]

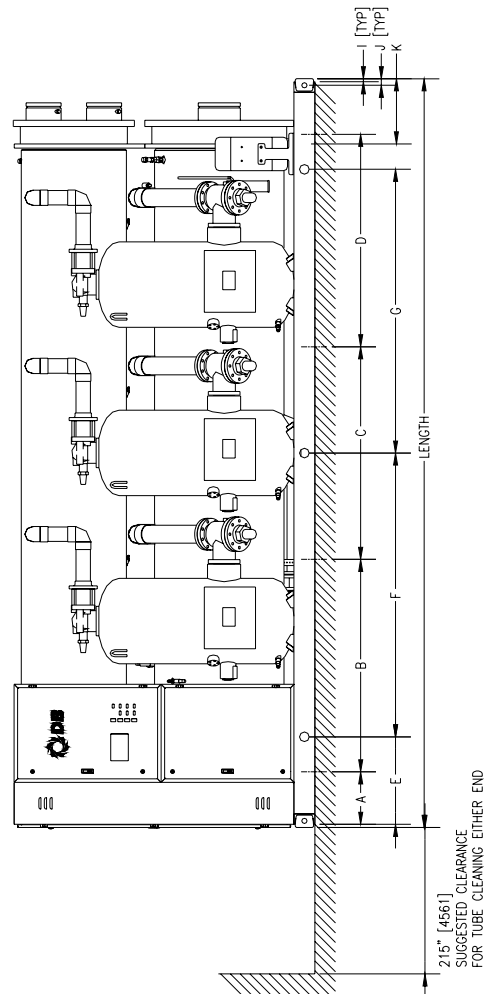
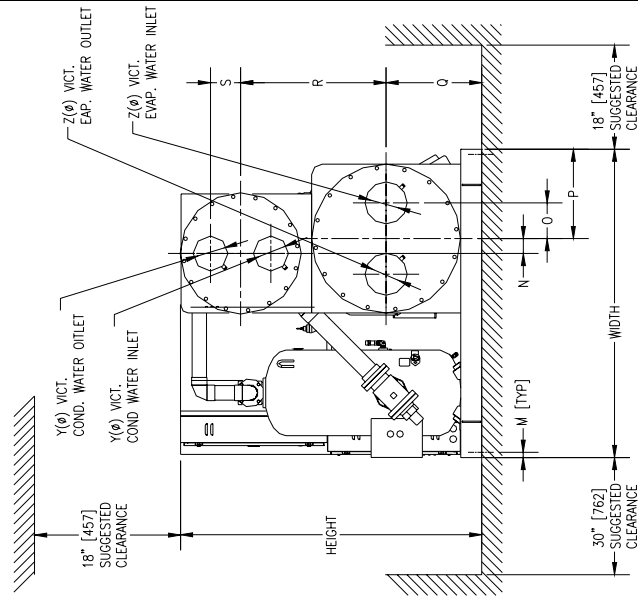

Notes : 1.) All dimensions are in inches[mm].
2.) Above drawing is for Superior model. Consult factory for Standard and Premium model dimension.

DIMENSIONAL DATA

WCFX-E 108, 113, 118, 123

MODEL	A	B	C	D	E	F	G	HEIGHT	I	J	K	LENGTH	M	N	O	P	Q	R	S	WIDTH	Y (Ø)	Z (Ø)
WCFX-E 108	20 [508]	53.5/16 [1355]	53.5/16 [1355]	53.5/16 [1355]	25 [635]	76 [1930]	74 [1880]	127 15/16 [3249]	7/8 [22]	1.7/8 [48]	17.7/8 [454]	201 3/4 [5124]	1.1/2 [38]	3.1/2 [89]	10 3/4 [273]	92 [2337]	35 5/16 [897]	51.11/16 [1312]	10 3/4 [273]	99 [2515]	14 [356]	14 [356]
WCFX-E 113	20 [508]	53.5/16 [1355]	53.5/16 [1355]	53.5/16 [1355]	25 [635]	76 [1930]	74 [1880]	127 15/16 [3249]	7/8 [22]	1.7/8 [48]	19.1/4 [489]	201 3/4 [5124]	1.1/2 [38]	3.1/2 [89]	10 3/4 [273]	92 [2337]	35 5/16 [897]	51.11/16 [1312]	10 3/4 [273]	99 [2515]	14 [356]	14 [356]
WCFX-E 118	20 [508]	52.7/16 [1331]	52.7/16 [1331]	52.7/16 [1331]	27 [686]	72.5/8 [1845]	72.5/8 [1845]	129 9/16 [3291]	7/8 [22]	1.7/8 [48]	17.7/8 [454]	199 [5055]	1.1/2 [38]	3.1/2 [89]	10 3/4 [273]	92 [2337]	35 5/16 [897]	53.5/8 [1361]	10 3/4 [273]	99 [2515]	14 [356]	14 [356]
WCFX-E 123	20 [508]	52.7/16 [1331]	52.7/16 [1331]	52.7/16 [1331]	27 [686]	72.5/8 [1845]	72.5/8 [1845]	129 9/16 [3291]	7/8 [22]	1.7/8 [48]	17.7/8 [454]	199 [5055]	1.1/2 [38]	3.1/2 [89]	10 3/4 [273]	92 [2337]	35 5/16 [897]	53.5/8 [1361]	10 3/4 [273]	99 [2515]	14 [356]	14 [356]

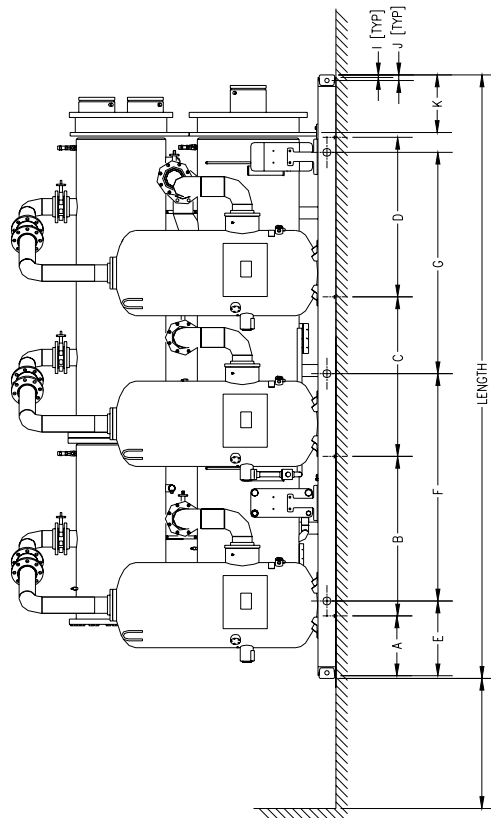
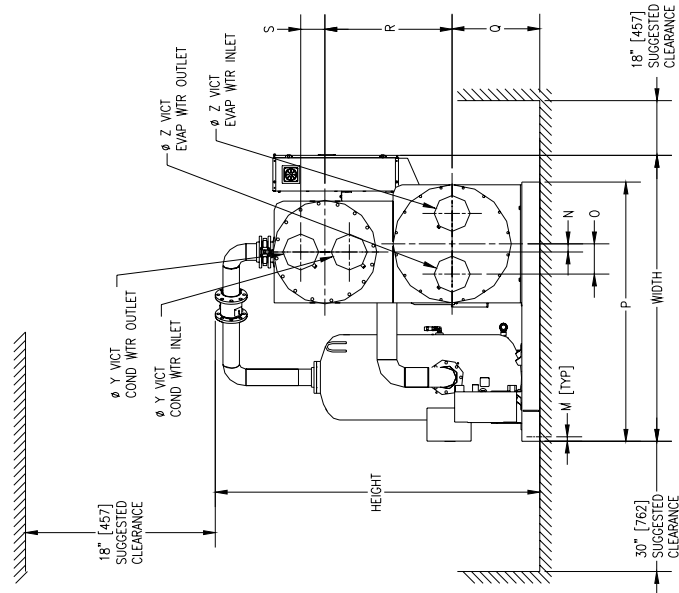

Notes : 1.) All dimensions are in inches[mm].
 2.) Above drawing is for Superior model. Consult factory for Standard and Premium model dimension.

FLOOR LOADING DIAGRAM

**WCFX-E 10S, 12S, 15S, 19S
20T, 22T, 24T, 27T, 30T**

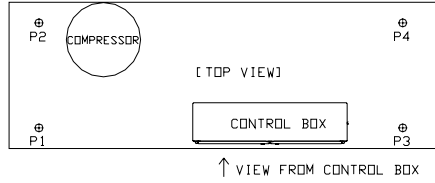

WCFX-E 108, 113, 118, 123

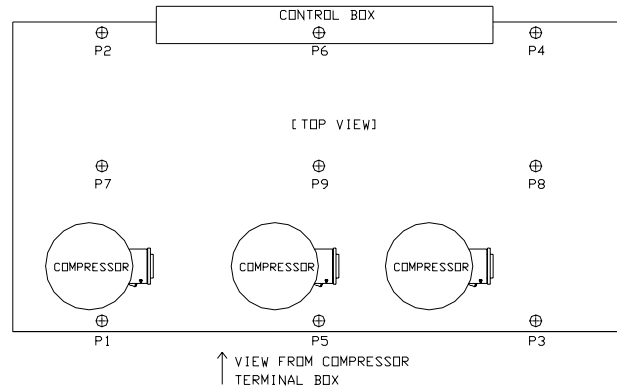

**WCFX-E 20S, 23S, 24S, 27S, 30S, 36S, 41S,
38T, 40T, 46T, 50T, 54T, 57T, 60T, 73T, 75T, 81T,
69, 73, 77, 81, 84, 87, 90**

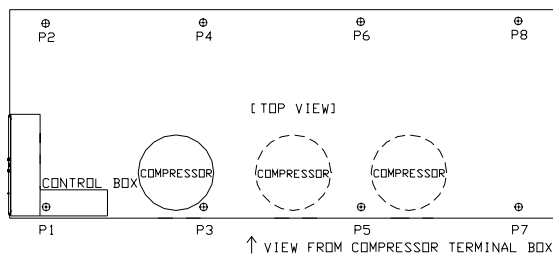

POINT LOAD DATA

Model WCFX-E	P1		P2		P3		P4		P5		P6		P7		P8		P9		Operating Weight	
	lbs	kg	lbs	kg	lbs	kg	lbs	kg	lbs	kg	lbs	kg	lbs	kg	lbs	kg	lbs	kg	lbs	kg
10S	1186	538	1845	837	930	422	1441	654	-	-	-	-	-	-	-	-	-	-	5402	2450
12S	1382	627	2150	975	1083	491	1679	762	-	-	-	-	-	-	-	-	-	-	6294	2855
15S	1452	659	2259	1025	1138	516	1764	800	-	-	-	-	-	-	-	-	-	-	6613	3000
19S	1131	513	1545	701	1034	469	1420	644	935	424	1296	588	838	380	1171	531	-	-	9370	4250
20S	1292	586	1934	877	1173	532	1764	800	1054	478	1595	724	935	424	1426	647	-	-	11173	5068
20T	1786	810	2892	1312	1742	790	2509	1138	-	-	-	-	-	-	-	-	-	-	8929	4050
22T	1940	880	3144	1426	1889	857	2727	1237	-	-	-	-	-	-	-	-	-	-	9700	4400
23S	1329	603	2023	918	1210	549	1846	837	1090	494	1670	757	970	440	1493	677	-	-	11631	5276
24S	1411	640	2106	955	1273	578	1918	870	1136	515	1731	785	999	453	1544	700	-	-	12118	5497
24T	2094	950	3391	1538	2039	925	2941	1334	-	-	-	-	-	-	-	-	-	-	10465	4747
27S	1468	666	2247	1019	1329	603	2049	929	1190	540	1850	839	1050	476	1651	749	-	-	12833	5821
27T	2238	1015	3622	1643	2178	988	3142	1425	-	-	-	-	-	-	-	-	-	-	11180	5071
30S	1621	735	2456	1114	1463	664	2238	1015	1305	592	2020	916	1147	520	1802	817	-	-	14052	6374
30T	2482	1126	4019	1823	2414	1095	3483	1580	-	-	-	-	-	-	-	-	-	-	12398	5624
36S	1709	775	2838	1287	1608	729	2653	1203	1507	684	2468	1120	1406	638	2283	1036	-	-	16473	7472
38T	1936	878	2357	1069	1793	813	2202	999	1651	749	2048	929	1510	685	1896	860	-	-	15393	6982
40T	2348	1065	2859	1297	2176	987	2672	1212	2004	909	2485	1127	1832	831	2297	1042	-	-	18673	8470
41S	1813	822	3055	1386	1705	773	2856	1296	1597	724	2658	1205	1489	676	2459	1115	-	-	17633	7998
46T	2337	1060	3057	1387	2233	1013	2875	1304	2129	966	2694	1222	2025	919	2512	1140	-	-	19863	9010
50T	2521	1144	3385	1536	2403	1090	3181	1443	2285	1036	2976	1350	2166	983	2771	1257	-	-	21688	9837
54T	2696	1223	3713	1684	2579	1170	3489	1583	2461	1116	3265	1481	2343	1063	3041	1380	-	-	23588	10699
57T	2811	1275	3809	1728	2698	1224	3590	1628	2585	1173	3371	1529	2472	1121	3151	1429	-	-	24486	11107
60T	2888	1310	3897	1768	2786	1264	3677	1668	2684	1218	3456	1568	2582	1171	3236	1468	-	-	25208	11434
69	3589	1628	4396	1994	3330	1511	4133	1875	3072	1393	3869	1755	2813	1276	3605	1635	-	-	28807	13067
73	3910	1773	4973	2256	3616	1640	4670	2118	3322	1507	4366	1981	3029	1374	4063	1843	-	-	31949	14492
73T	3733	1693	4850	2200	3255	1476	4464	2025	2777	1259	4077	1849	2298	1042	3690	1674	-	-	29144	13220
75T	3840	1742	5012	2274	3354	1521	4615	2094	2868	1301	4219	1914	2382	1080	3822	1734	-	-	30111	13658
77	3983	1807	5033	2283	3688	1673	4727	2144	3393	1539	4421	2005	3098	1405	4115	1867	-	-	32458	14723
81	4205	1907	5454	2474	3910	1773	5125	2325	3614	1639	4796	2175	3318	1505	4467	2026	-	-	34889	15825
81T	4082	1852	5504	2497	3582	1625	5076	2302	3082	1398	4647	2108	2582	1171	4218	1913	-	-	32773	14866
84	4441	2014	5750	2608	4132	1874	5411	2454	3823	1734	5072	2300	3514	1594	4732	2147	-	-	36873	16725
87	4538	2059	5845	2651	4228	1918	5502	2495	3917	1777	5158	2340	3606	1635	4815	2184	-	-	37608	17059
90	4659	2113	6050	2744	4358	1977	5698	2585	4058	1841	5346	2425	3758	1704	4994	2265	-	-	38920	17654
108	4596	2085	4993	2265	4795	2175	5348	2426	4696	2130	5171	2345	4776	2166	5053	2292	4914	2229	44342	20113
113	4713	2138	5141	2332	4946	2243	5523	2505	4830	2191	5332	2419	4908	2226	5215	2366	5062	2296	45669	20715
118	5150	2336	5729	2598	5430	2463	6176	2801	5290	2400	5953	2700	5419	2458	5785	2624	5602	2541	50533	22921
123	5322	2414	5919	2685	5581	2532	6363	2886	5452	2473	6141	2786	5599	2540	5955	2701	5777	2620	52109	23636

Notes: 1.) Refer to dimensional drawings for location of mounting points.
2.) Unit must be lowered onto mounting springs in a level fashion or spring damage may occur.

WATER PRESSURE DROP

IMPERIAL UNITS

1A.) EVAPATOR 1 PASS

a.) Single Compressor

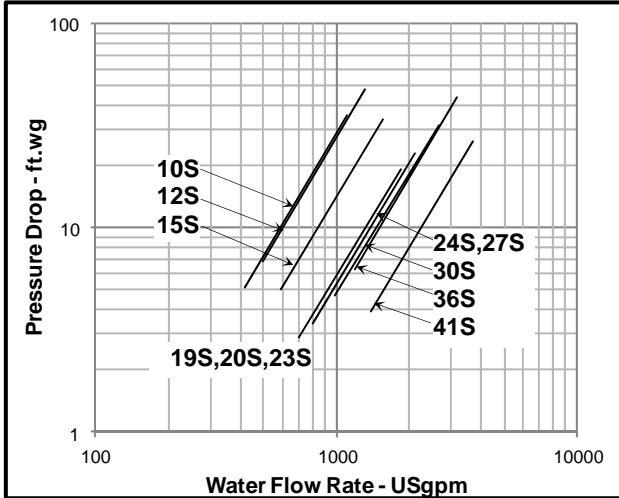

1B.) EVAPATOR 2 PASS

a.) Single Compressor

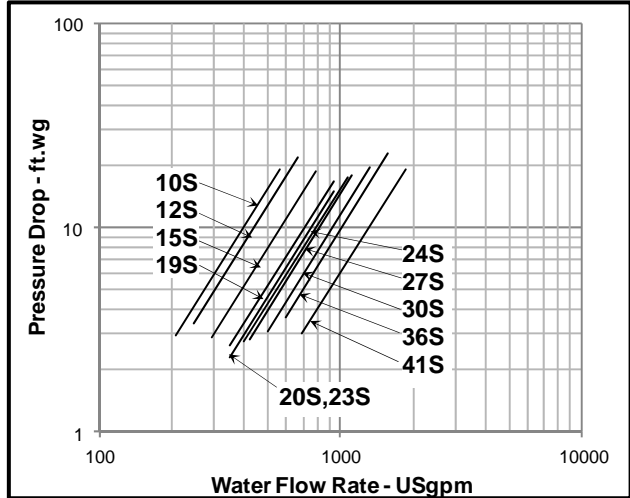

b.) Twin Compressors

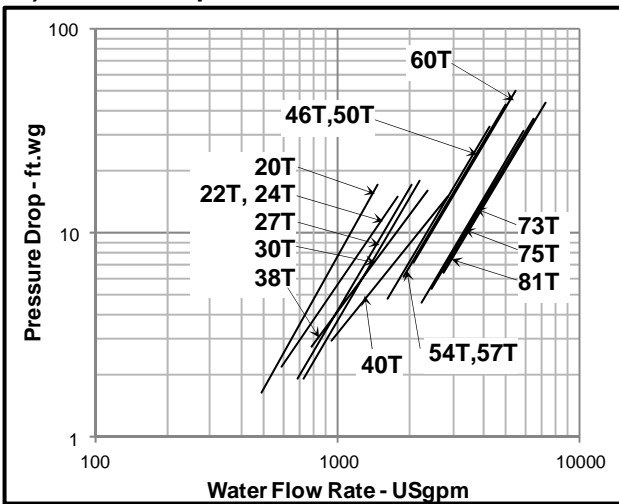

b.) Twin Compressors

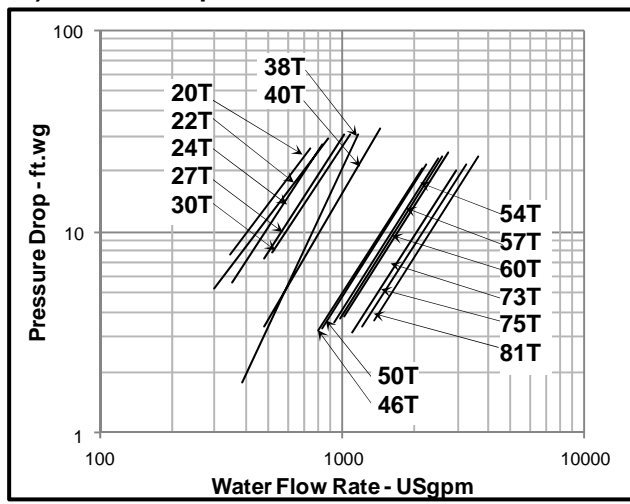

c.) Three Compressors

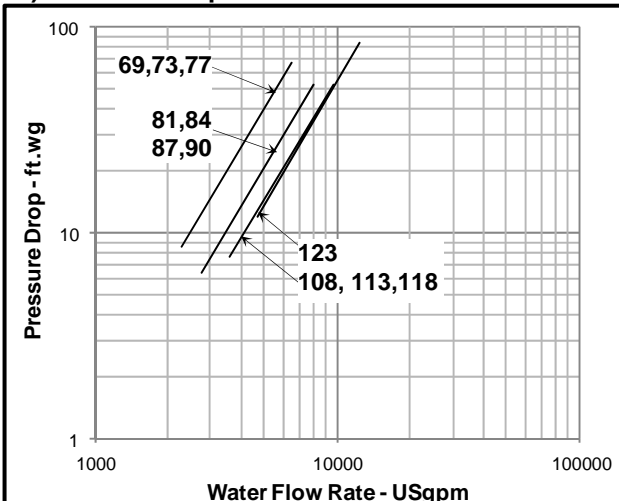

c.) Three Compressors

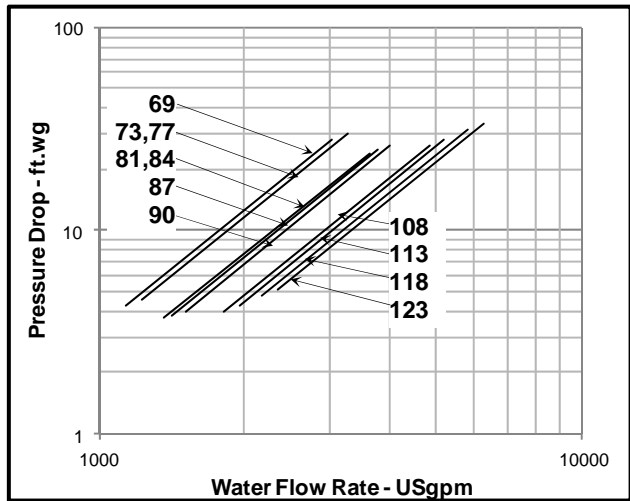

Note : Above water pressure drop is for Superior model. Consult factory for Standard and Premium model.

WATER PRESSURE DROP

IMPERIAL UNITS

1C.) EVAPORATOR - 3 PASS

a.) Single Compressor

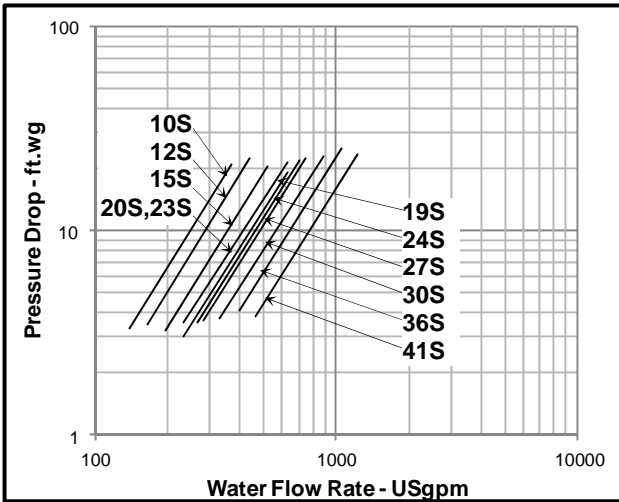

b.) Twin Compressors

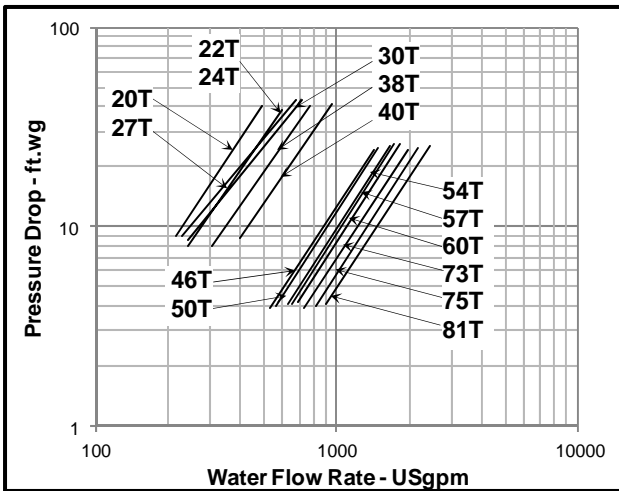

c.) Three Compressors

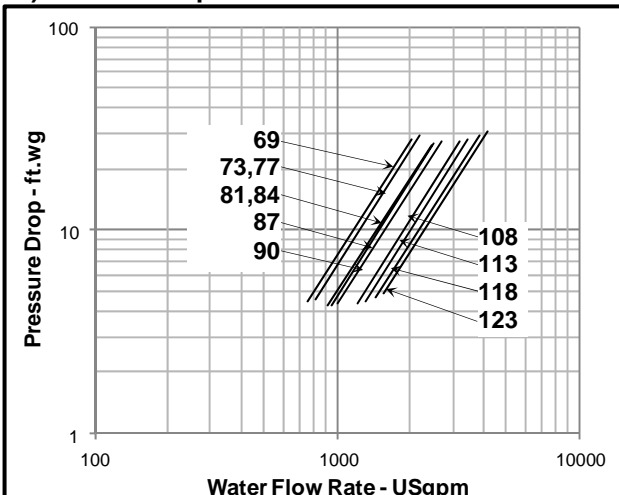

2A.) CONDENSER - 1 PASS

a.) Single Compressor

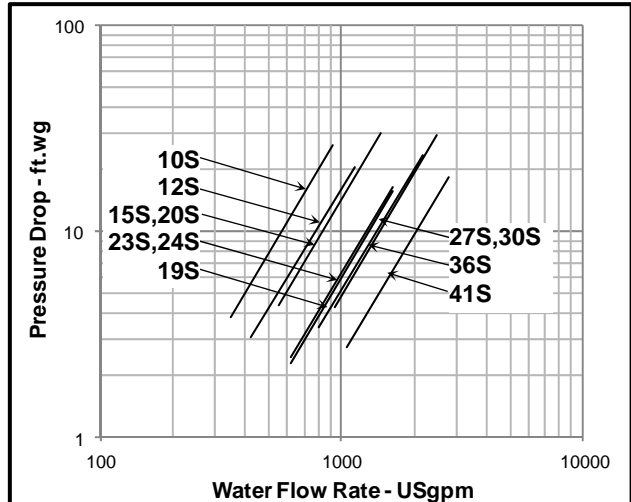

b.) Twin Compressors

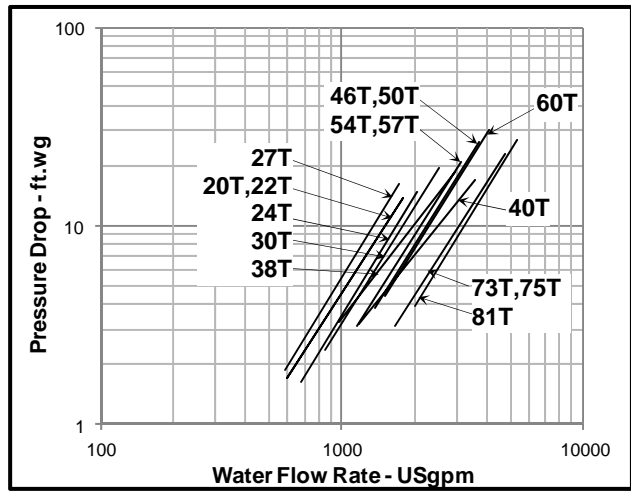

c.) Three Compressors

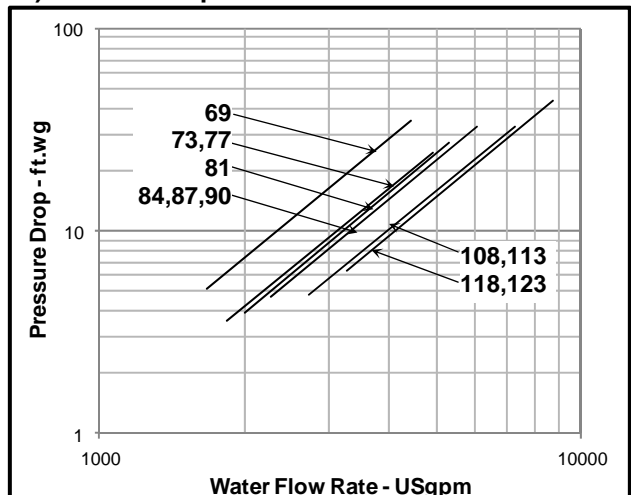

Note : Above water pressure drop is for Superior model. Consult factory for Standard and Premium model.

WATER PRESSURE DROP

IMPERIAL UNITS

2B.) CONDENSER 2 PASS

a.) Single Compressor

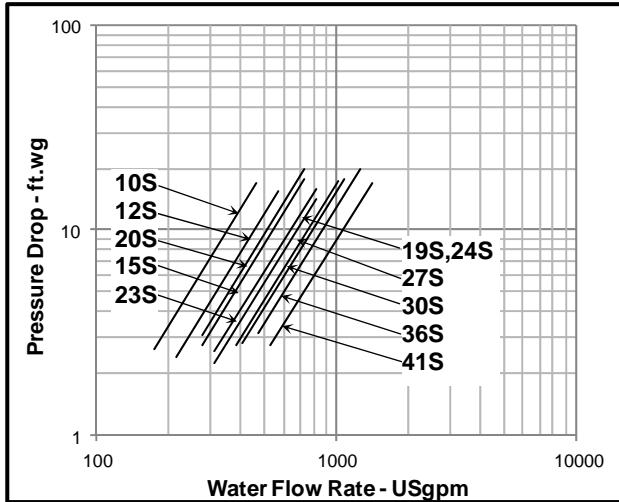

2C.) CONDENSER 3 PASS

a.) Single Compressor

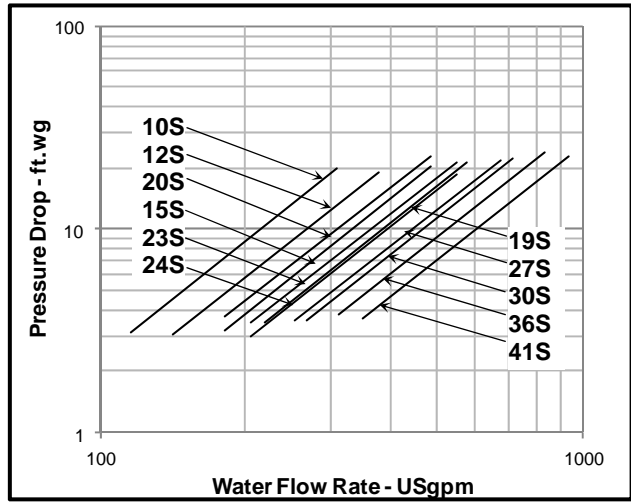

b.) Twin Compressors

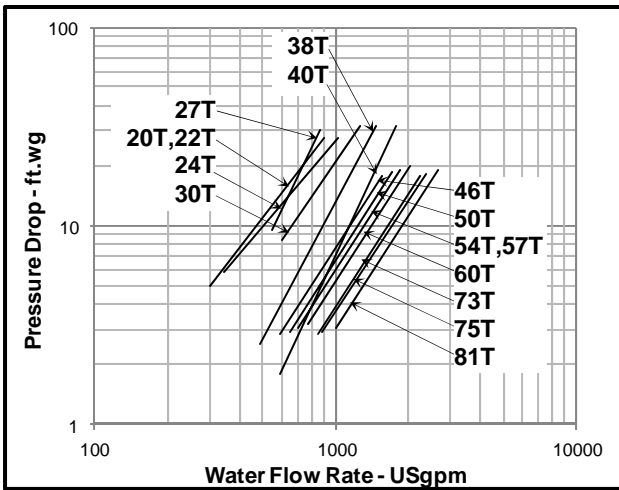

b.) Twin Compressors

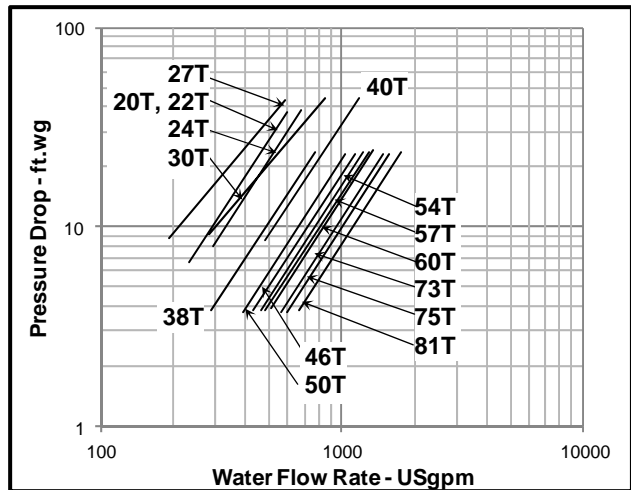

c.) Three Compressors

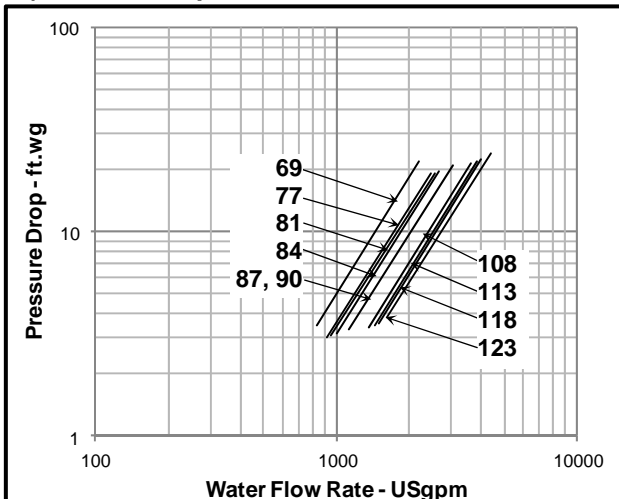

c.) Three Compressors

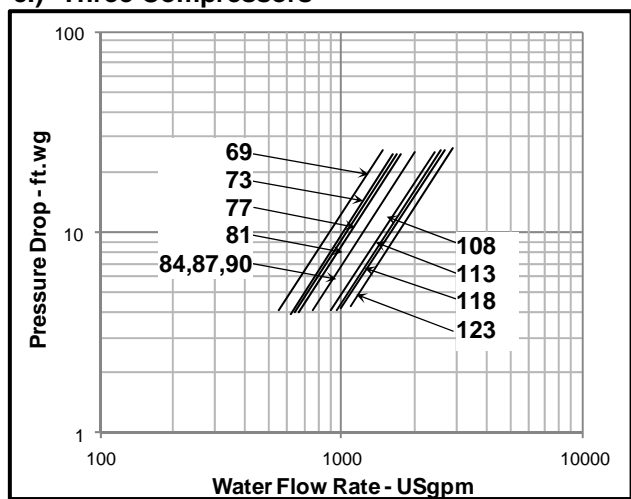

Note : Above water pressure drop is for Superior model. Consult factory for Standard and Premium model.

WATER PRESSURE DROP

SI UNITS

1A.) EVAPATOR 1 PASS

a.) Single Compressor

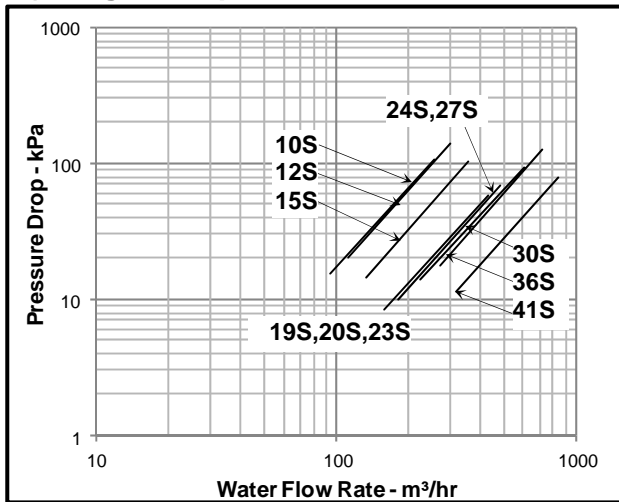

1B.) EVAPATOR 2 PASS

a.) Single Compressor

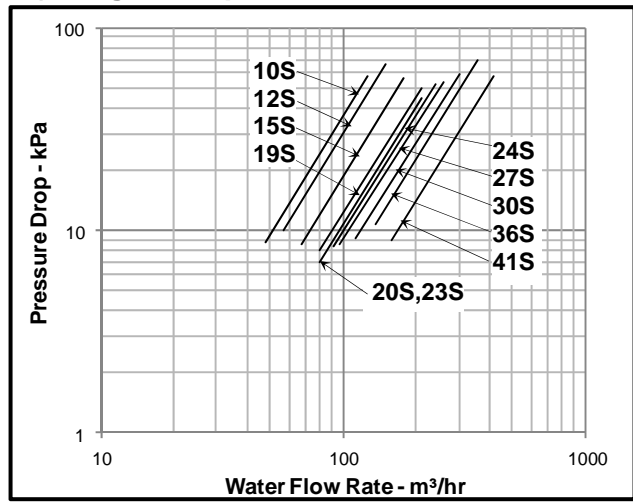

b.) Twin Compressors

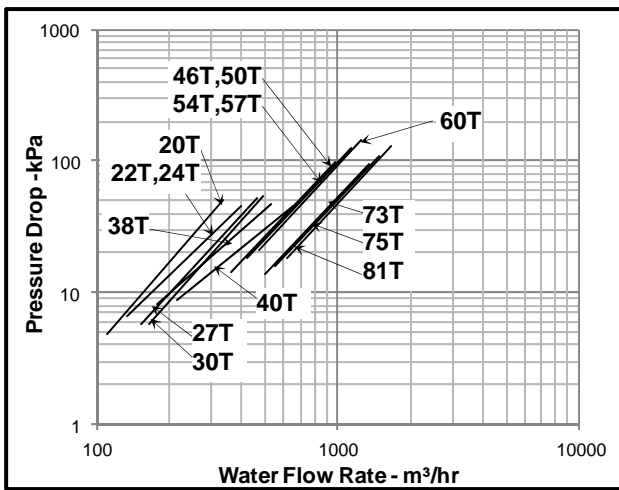

b.) Twin Compressors

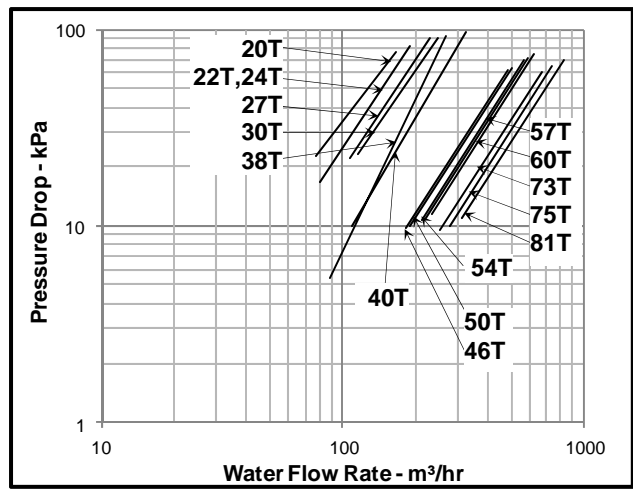

c.) Three Compressors

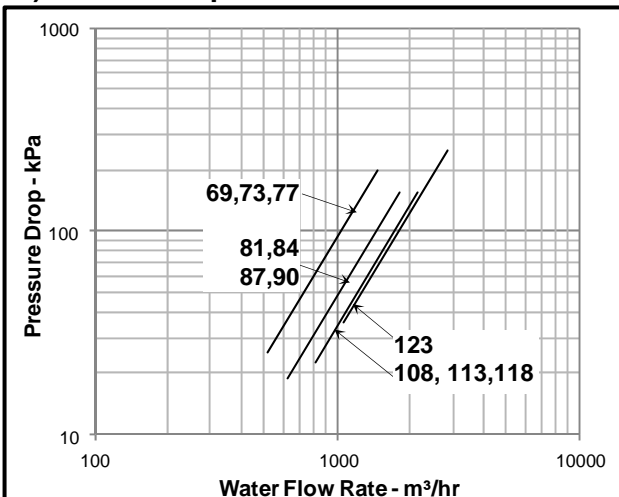

c.) Three Compressors

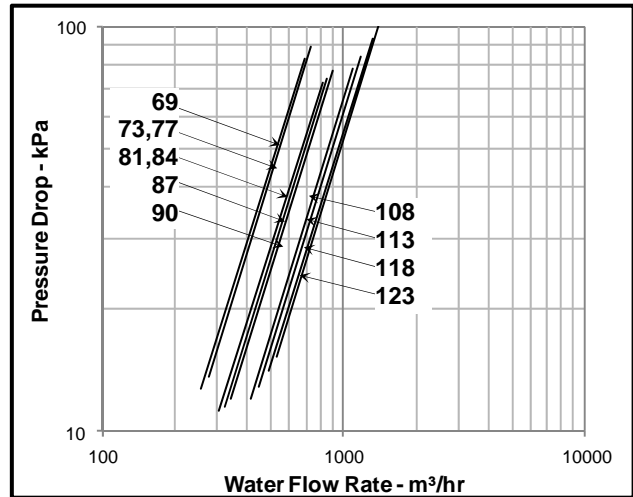

Note : Above water pressure drop is for Superior model. Consult factory for Standard and Premium model.

WATER PRESSURE DROP

SI UNITS

1C.) EVAPORATOR - 3 PASS

a.) Single Compressor

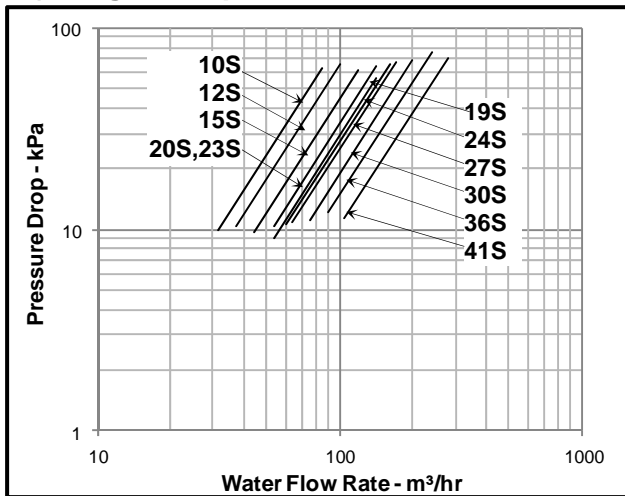

2A.) CONDENSER - 1 PASS

a.) Single Compressor

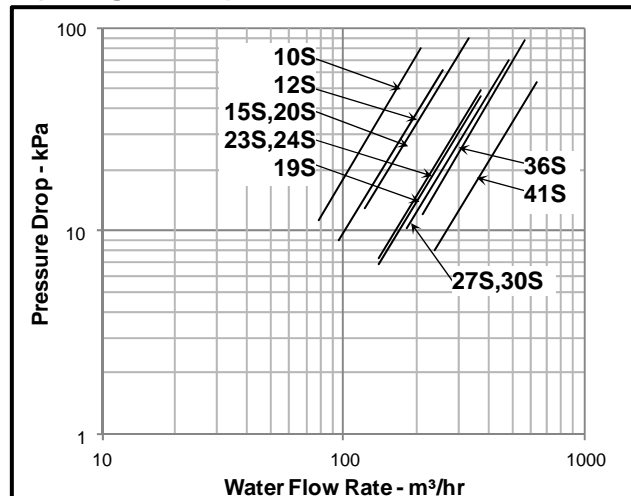

b.) Twin Compressors

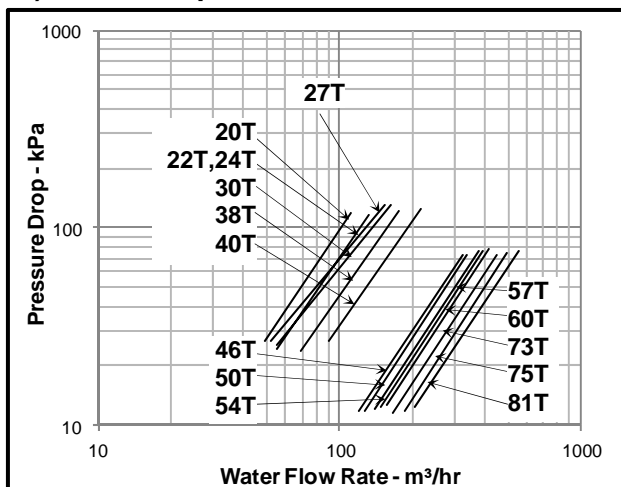

b.) Twin Compressors

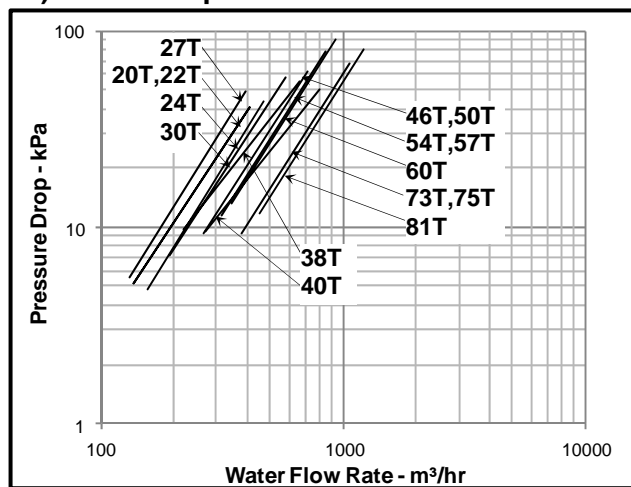

c.) Three Compressors

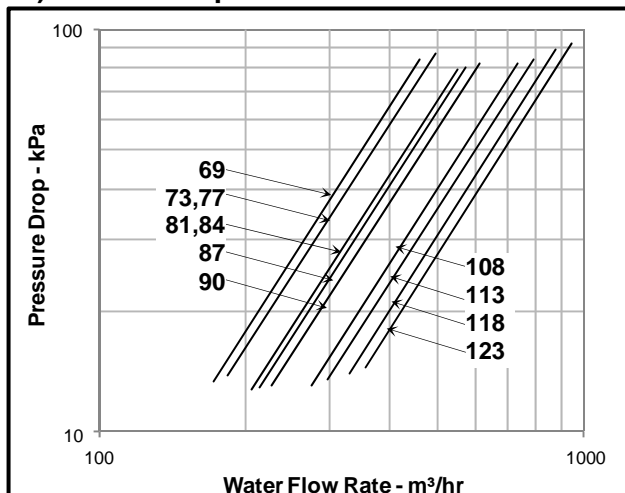

c.) Three Compressors

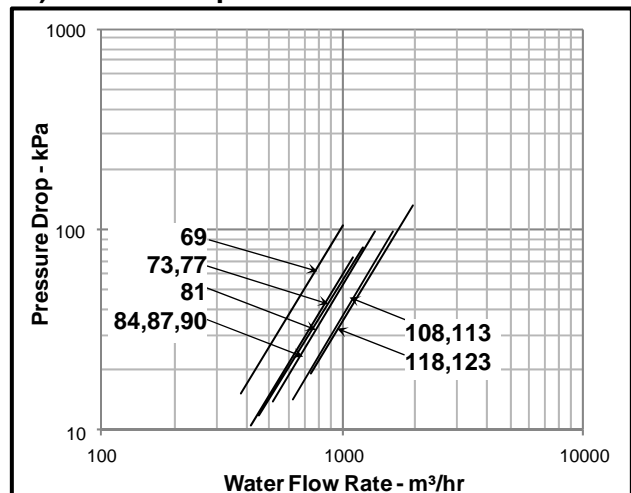

Note : Above water pressure drop is for Superior model. Consult factory for Standard and Premium model.

WATER PRESSURE DROP

SI UNITS

2B.) CONDENSER 2 PASS

a.) Single Compressor

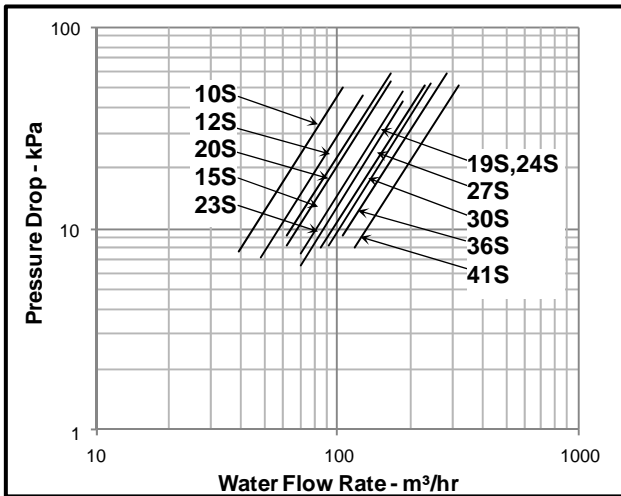

2C.) CONDENSER 3 PASS

a.) Single Compressor

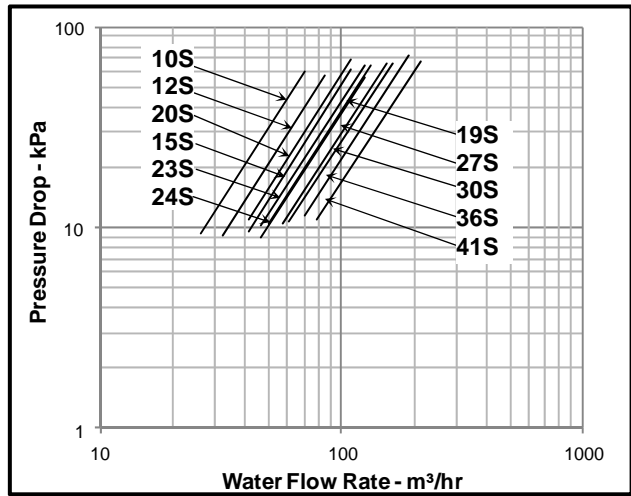

b.) Twin Compressors

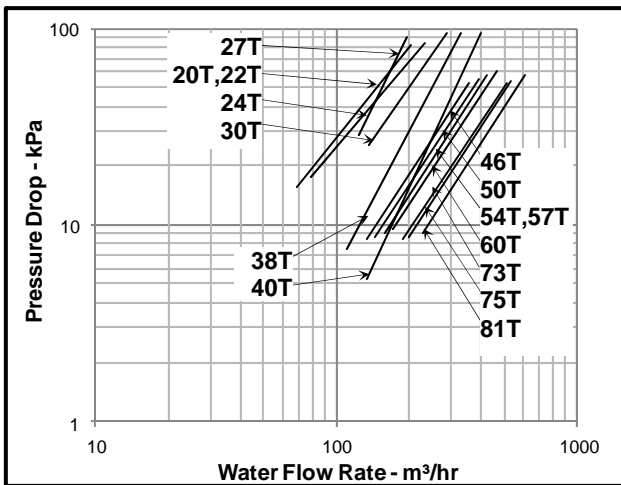

b.) Twin Compressors

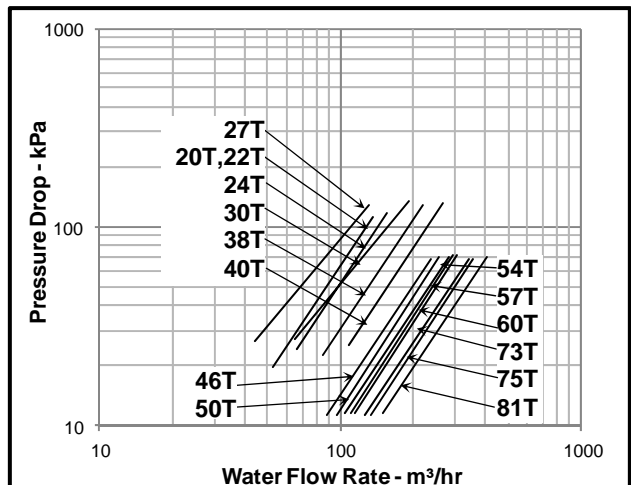

c.) Three Compressors

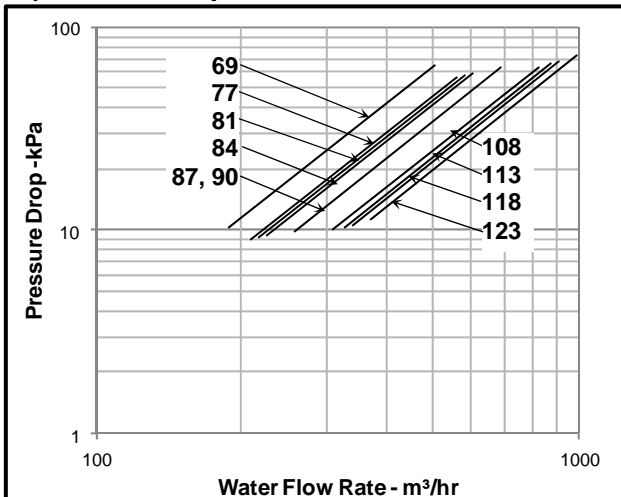

c.) Three Compressors

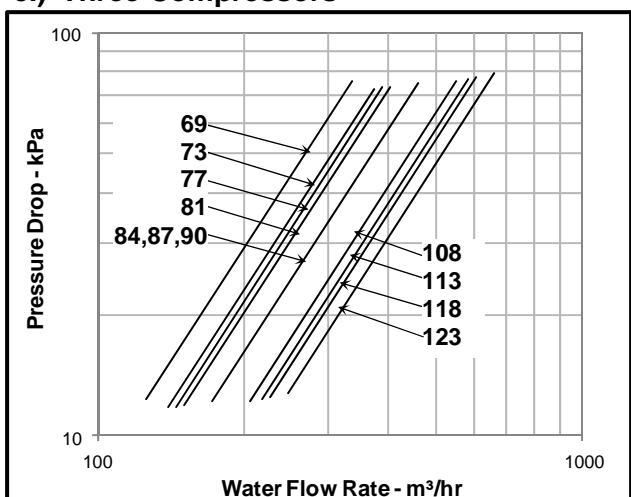

Note : Above water pressure drop is for Superior model. Consult factory for Standard and Premium model.



SOUND PRESSURE DATA

Model WCFX-E	Octave Band (Hz)								TOTAL dB (A)
	63	125	250	500	1K	2K	4K	8K	
10S	70	55	59	67	75	72	62	53	78
12S	71	56	60	68	76	73	63	54	79
15S	71	59	63	71	79	76	66	57	82
19S	68	57	63	68	75	72	72	54	79
20S	68	57	63	68	75	72	72	54	79
20T	72	57	61	69	77	74	64	55	80
22T	72	57	61	69	77	74	64	55	80
23S	68	57	63	68	75	72	72	54	79
24S	69	59	64	68	76	73	74	56	80
24T	73	58	62	70	78	75	65	56	81
27S	69	59	64	68	76	73	74	56	80
27T	73	59	63	71	79	76	66	57	82
30S	70	61	65	69	78	75	74	59	81
30T	73	61	65	73	81	78	68	59	84
36S	70	61	65	69	78	75	74	59	81
38T	71	60	66	71	78	75	75	57	82
40T	70	59	65	70	77	74	74	56	81
41S	70	61	65	69	78	75	74	59	81
46T	70	59	65	70	77	74	74	56	81

Model WCFX-E	Octave Band (Hz)								TOTAL dB (A)
	63	125	250	500	1K	2K	4K	8K	
50T	71	60	66	70	78	75	75	57	82
54T	71	61	66	70	78	75	76	58	82
57T	71	62	66	70	79	76	76	60	83
60T	72	63	67	71	80	77	76	61	83
69	71	60	66	71	78	75	75	57	82
73	72	61	67	71	79	76	76	58	83
73T	72	63	67	71	80	77	76	61	83
75T	72	63	67	71	80	77	76	61	83
77	72	62	67	71	79	76	77	59	83
81	72	62	67	71	79	76	77	59	84
81T	72	63	67	71	80	77	76	61	83
84	73	63	68	72	80	77	77	61	84
87	73	64	68	72	81	78	77	62	85
90	73	64	68	72	81	78	77	62	85
108	73	64	68	72	81	78	77	62	84
113	73	64	68	72	81	78	77	62	84
118	73	64	68	72	81	78	77	62	84
123	73	64	68	72	81	78	77	62	84

Note: Sound Pressure Level dB(A) @ 3.3ft [1m] (free field) ± 2dB.

ELECTRICAL DATA

Model WCFX-E	Unit			Compressor			
	Power Supply	Max. Fuse Size	Min. Circuit Ampacity	Compressor Model	RLA	Inrush Amps	LRA
10S	460VAC±10%	200	100	1210(1)	78	283	425
12S	460VAC±10%	300	100	1212(1)	104	392	588
15S	460VAC±10%	400	200	1215(1)	129	429	644
19S	460VAC±10%	400	200	1220(1)	126.0	408.3	612.4
20S	460VAC±10%	400	200	1222(1)	154	499	749
20T	460VAC±10%	300	200	1210(2)	78.0(2)	283.0(2)	424.5(2)
22T	460VAC±10%	400	200	1210(1) / 1212(1)	78.0 / 104.0	283.0 / 392.0	424.5 / 588.0
23S	460VAC±10%	400	200	1222(1)	154	499	749
24S	460VAC±10%	600	200	1227(1)	193	615	923
24T	460VAC±10%	400	300	1212(2)	104.0(2)	392.0(2)	588.0(2)
27S	460VAC±10%	600	200	1227(1)	193	615	923
27T	460VAC±10%	500	300	1212(1) / 1215(1)	104.0 / 129.0	392.0 / 429.0	588.0 / 643.5
30S	460VAC±10%	700	300	1230(1)	224	679	1019
30T	460VAC±10%	500	300	1215(2)	129.0(2)	429.0(2)	643.5(2)
36S	460VAC±10%	700	300	2233 (1)	259	920	1380
38T	460VAC±10%	500	300	1220(2)	126.0(2)	408.3(2)	612.4(2)
40T	460VAC±10%	600	400	1222(2)	154.0(2)	499.0(2)	748.5(2)
41S	460VAC±10%	900	400	2236 (1)	309	1214	1821
46T	460VAC±10%	600	400	1222(2)	154(2)	499(2)	749(2)
50T	460VAC±10%	800	400	1227(1) / 1222(1)	193 / 154	615 / 499	923 / 749
54T	460VAC±10%	800	500	1227(2)	193(2)	615(2)	923(2)
57T	460VAC±10%	900	500	1230(1) / 1227(1)	224 / 193	679 / 615	1019 / 923
60T	460VAC±10%	900	600	1230(2)	224(2)	679(2)	1019(2)
69	460VAC±10%	800	600	1222(3)	154(3)	499(3)	749(3)
73	460VAC±10%	1000	600	1227(1) / 1222(2)	193(1) / 154(2)	615 / 499(2)	923 / 749(2)
73T	460VAC±10%	1000	600	2233(2)	259(2)	920(2)	1380(2)
75T	460VAC±10%	1200	700	2236(1) / 2233(1)	309 / 259	1214 / 920	1821 / 1380
77	460VAC±10%	1000	700	1227(2) / 1222(1)	193(2) / 154	615(2) / 499	923(2) / 749
81	460VAC±10%	1100	700	1227(3)	193(3)	615(3)	923(3)
81T	460VAC±10%	1300	800	2236(2)	309(2)	1214(2)	1821(2)
84	460VAC±10%	1200	800	1230(1) / 1227(2)	224 / 193(2)	679 / 615(2)	1019 / 923(2)
87	460VAC±10%	1200	800	1230(2) / 1227(1)	224(2) / 193	679(2) / 615	1019(2) / 923
90	460VAC±10%	1200	900	1230(3)	224(3)	679(3)	1019(3)
108	460VAC±10%	1400	1000	2233(3)	259(3)	920(3)	1380(3)
113	460VAC±10%	1500	1000	2236(1) / 2233(2)	309 / 259(2)	1214 / 920(2)	1821 / 1380(2)
118	460VAC±10%	1600	1100	2236(2) / 2233(1)	309(2) / 259	1214(2) / 920	1821(2) / 1380
123	460VAC±10%	1600	1200	2236(3)	309(3)	1214(3)	1821(3)

Note: RLA – Rated Load Amps

LRA – Locked Rotor Amps

TYPICAL WIRING SCHEMATIC

Two Compressors Unit

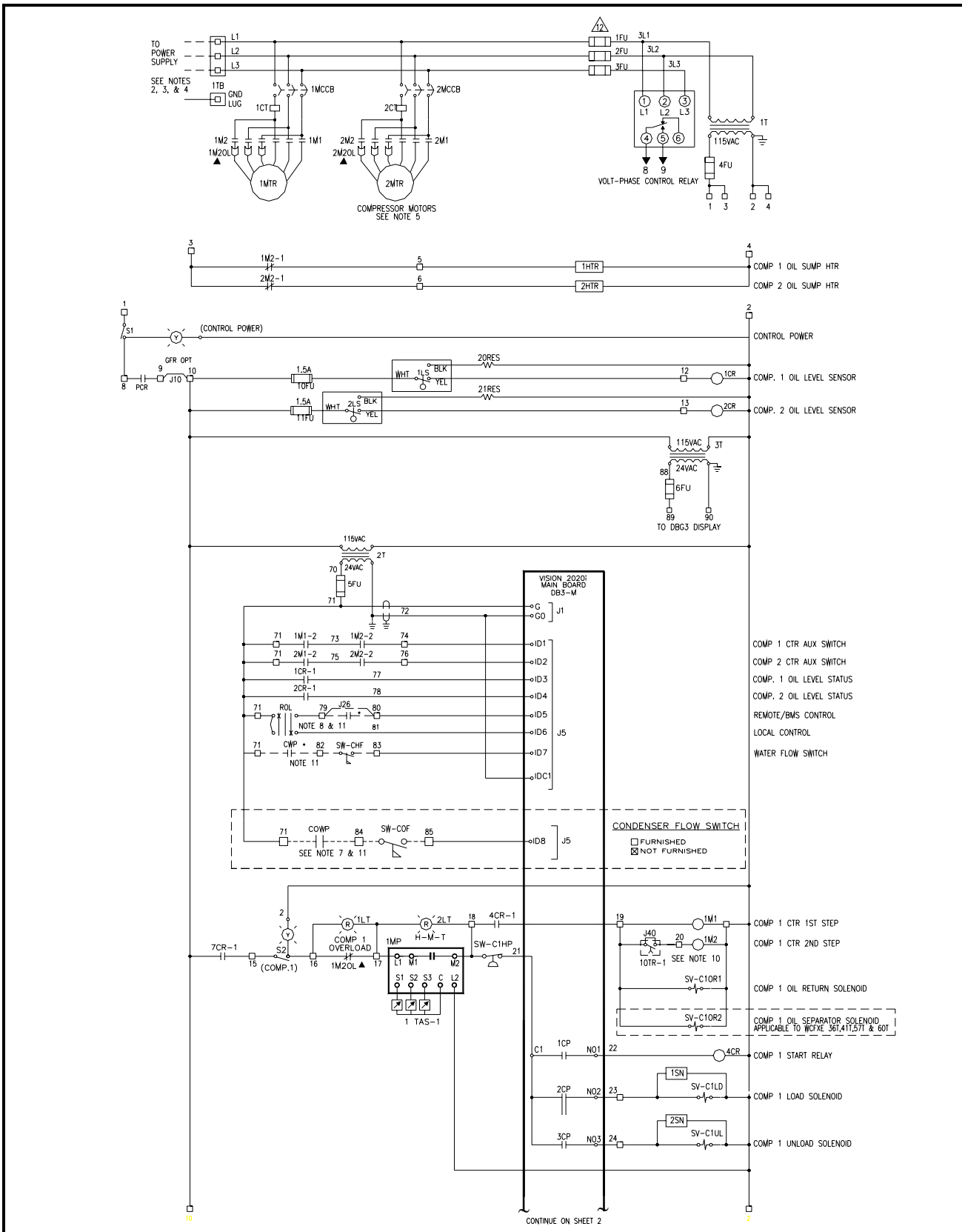

TYPICAL WIRING SCHEMATIC

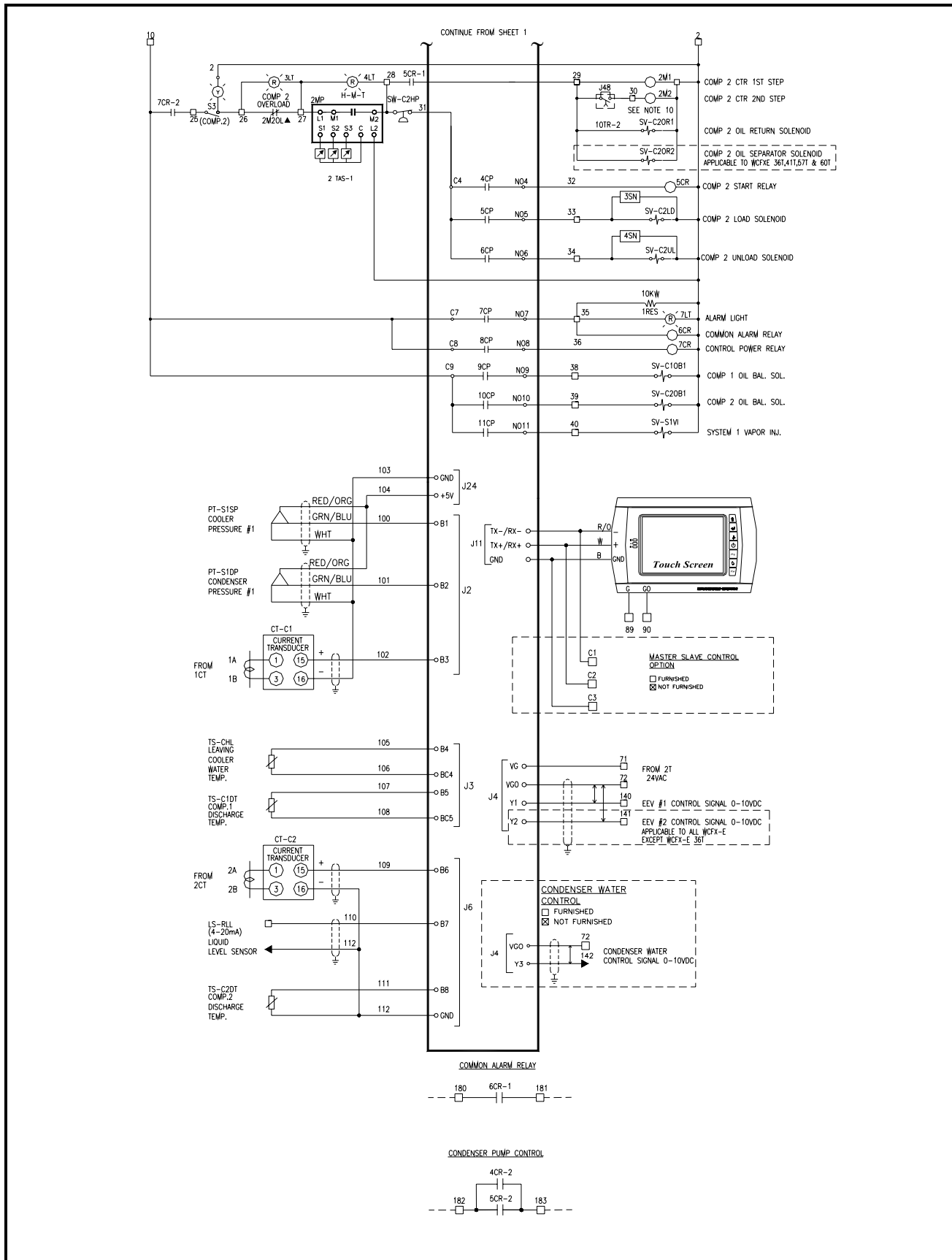

TYPICAL WIRING SCHEMATIC

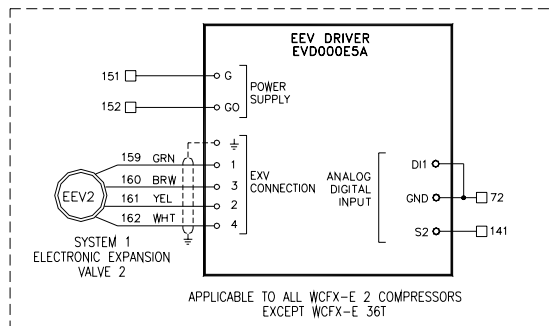
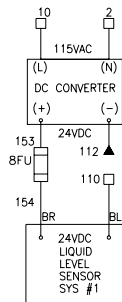
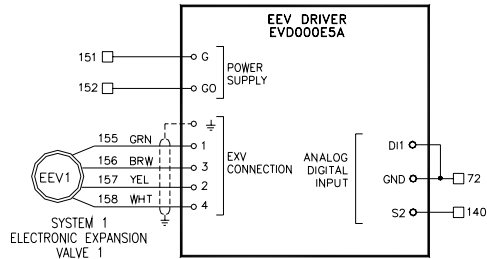
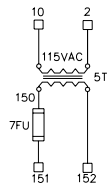

NOTES

- 1- FUSES SHALL BE TIME DELAY TYPE.
- 2- ALL FIELD WIRING SHALL COMPLY WITH LOCAL, STATE AND NATIONAL CODES.
- 3- USE COPPER CONDUCTORS ONLY. CONTROL WIRING 14AWG.
- 4- DISCONNECT MEANS AND BRANCH CIRCUIT PROTECTION SHALL BE PROVIDED BY INSTALLER.
- 5- IF POWER SUPPLY HAS BEEN INTERRUPTED FOR A PROLONGED PERIOD, OIL SUMP HEATERS MUST BE ENERGIZED FOR 24 HOURS MINIMUM BEFORE STARTING COMPRESSORS.
- 6- DO NOT RUN CT WIRES IN WIRE BUNDLES.
- 7- CHILLED WATER FLOW SWITCH AND PUMP INTERLOCK ARE REQUIRED. DO NOT USE THESE SWITCHES TO CONTROL THE PACKAGE.
- 8- BMS CONTROL CONTACTS MUST BE WIRED BETWEEN THESE TERMINALS. SELECT POSITION "R" FOR REMOTE START, POSITION "O" FOR UNIT SHUT DOWN AND POSITION "L" FOR LOCAL START. JUMPER BOTH TERMINAL IF BMS USING ONLY HIGH LEVEL CONTROL.
- 9- IF 4-20mA CWR IS USED, SET SETPOINT TO RESET DESIRED AT 20mA INPUT.
CAUTION: DO NOT SUPPLY OVER 20mA TO INPUT TERMINAL.
2RES CAN BE WIRED BETWEEN TERMINALS 89 & 90 OR BETWEEN TERMINALS 10TR TIMER JUMPER WIRE IS A CUSTOMER OPTION TO TAKE OUT OR KEEP IN.
- 10- THE SHIELDED CABLES ARE RECOMMENDED FOR FIELD INSTALLED CONTROL & SIGNAL WIRING. CONNECT ONE END OF THE SHIELD TO GROUND.
- 12- DRY CONTACT FROM CUSTOMER TO ENABLE ICE MODE. DEFAULT IS CHILLER MODE
- 13- DRY CONTACT FROM CUSTOMER TO ENABLE HEATING MODE. DEFAULT IS CHILLER MODE

LEGEND

AI	ANALOG INPUT
AM	AMMETER
CB	CIRCUIT BREAKER
COMP	COMPRESSOR
CP	CONTROL POINT
CPR	CAPACITOR
CR	CONTROL RELAY
CT	CURRENT TRANSFORMER
CTR	CONTACTOR
CWP	CHILLED WATER PUMP
CWR	CHILLED WATER RESET
D	DIGITAL INPUT
DI	DIGITAL INPUT
FS	FLOAT SWITCH
FU	FUSE
GND	GROUND
H-O-T	HIGH OIL TEMP
HMT	HIGH MOTOR TEMP
HTR	HEATER
I/O	INPUT/OUTPUT
LD	LEAK DETECTOR
LS	LEVEL SENSOR
LT	LIGHT
M	CONTACTOR
MCS	MOLDED CASE SWITCH
MOV	METAL OXIDE VARISTOR
MTR	MOTOR
NC	NORMALLY CLOSED
NO	NORMALLY OPEN
OL	OVERLOAD
PB	PUSH BUTTON
PT	PRESSURE TRANSDUCER
RES	RESISTOR
R-O-L	REMOTE-OFF-LOCAL
RLY	RELAY
SS	PUMP DOWN SWITCH
SC	STARTS COUNTER
SH	SHIELD
SN	SNUBBER
SOL	SOLENOID
SW-CHF	CHILLED WATER FLOW SWITCH
TAS	THERMOSTAT
TB	TERMINAL BLOCK
TLW	TEMP LEAVING WATER
TR	TIMER
TS	TEMP. SENSOR
UVR	UNDERVOLTAGE RELAY
VF	VENTILATION FAN
VM	VOLTMETER
ZD	ZENOR DIODE
ZR	MANUAL RESET
□	FACTORY TERMINAL
—	FIELD WIRING
*	FIELD SUPPLIED

TYPICAL WIRING SCHEMATIC

MAIN DISCONNECT SWITCH OPTION

- FURNISHED
- NOT FURNISHED

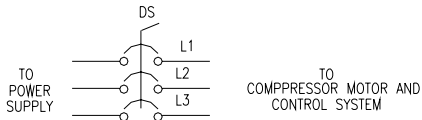

BMS COMMUNICATION OPTION

MODBUS RS485 RTU

- FURNISHED
- NOT FURNISHED

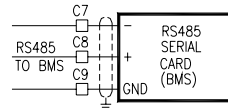

MODBUS OVER IP

- FURNISHED
- NOT FURNISHED



3 PHASE AMMETER OPTION

- FURNISHED
- NOT FURNISHED

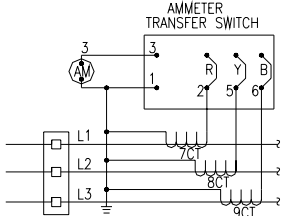

GROUND FAULT RELAY

- FURNISHED
- NOT FURNISHED

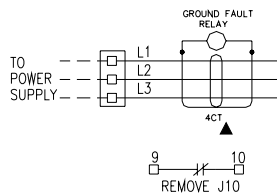

BACNET MS/TP OPTION

- FURNISHED
- NOT FURNISHED

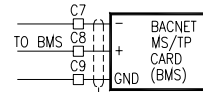

BACNET OVER IP OPTION

- FURNISHED
- NOT FURNISHED

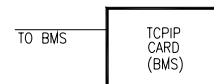

* PLEASE REFER TO UNIT IOM FOR PROCEDURE TO INSERT THE CARD TO THE VISION 2020i DB3 MAIN CONTROLLER

** ONLY ONE OPTION CAN BE CHOSEN IN THIS SECTION

DOOR LATCH SOLENOIDS OPTION

- FURNISHED
- NOT FURNISHED

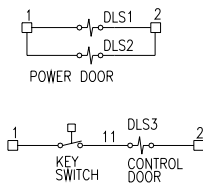

ALARM BELL

- FURNISHED
- NOT FURNISHED

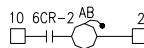

LONWORK OPTION

- FURNISHED
- NOT FURNISHED

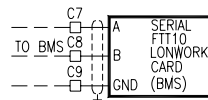

MODEM OPTION

- FURNISHED
- NOT FURNISHED

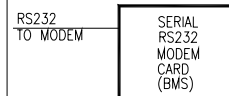

3 PHASE VOLTMETER OPTION

- FURNISHED
- NOT FURNISHED

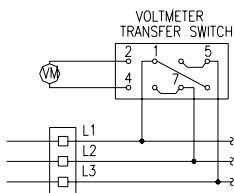

COMPRESSOR RUN SIGNAL

- FURNISHED
- NOT FURNISHED

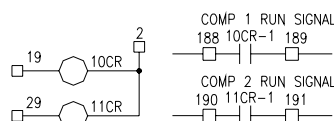

DB LINK/BACNET PTP/GTY/TCPIP GTY/PLANVISOR OPTION

- FURNISHED
- NOT FURNISHED

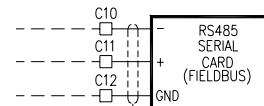

TYPICAL WIRING SCHEMATIC

DBLAN NETWORK (MASTER-SLAVE CONTROL OPTION)

- FURNISHED
- NOT FURNISHED

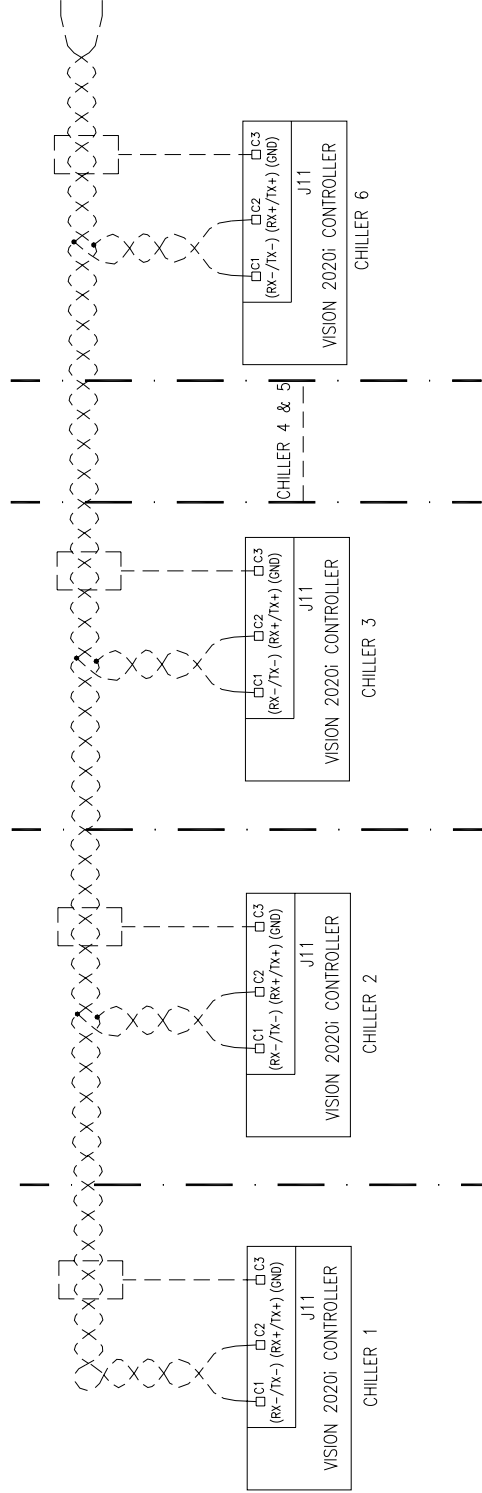

NOTES:

- 1- TERMINAL BLOCK OF C1, C2 & C3 OF EACH VISION 2020: CONTROLLER MUST BE INTERCONNECTED WITH AN AWG 20/22 SHIELDED CABLE MADE UP OF A TWISTED PAIR PLUS SHIELD. THE CONTROLLERS ARE CONNECTED IN PARALLEL, WITH TERMINAL J11 AS THE REFERENCE NETWORK PARALITY: RX-/TX- ON ONE CONTROLLER MUST BE CONNECTED TO RX-/TX- ON THE OTHER CONTROLLERS, THE SAME TRUE FOR RX+/TX+ AND GND

- 2- IF FURNISHED MASTER-SLAVE CONTROL OPTION
FURNISHED CHILLED WATER PUMP CONTROL OPTION

CHILLER CONTROLLER ADDRESS SETTING

CHILLER NO.	UNIT NO.	VISION 2020: CONTROLLER ADDRESS SETTING	DBG3 DISPLAY ADDRESS SETTING
CHILLER 1	1	1	17
CHILLER 2	2	2	18
CHILLER 3	3	3	19
CHILLER 4	4	4	20
CHILLER 5	5	5	21
CHILLER 6	6	6	22

APPLICATION DATA

HEAT RECOVERY

The Dunham-Bush Water Cooled Screw Flooded Chiller can significantly reduce building operating costs when the heat recovery option is selected. Any building which requires simultaneous heating and cooling may be an excellent candidate for this system.

Hotter Hot Water

Most centrifugal water chillers are limited in producing leaving condenser water temperatures to 105°F or below. Dunham-Bush Water Cooled Screw Flooded Chillers are able to provide leaving water temperatures over 120°F allowing for the installation of smaller heating coils at a lower first cost than systems utilizing centrifugal water chillers. The warmer supply air temperatures available will also improve tenant comfort.

Greater Design Flexibility

Centrifugal water chillers are susceptible to surge conditions during part-load operation and need to be selected to operate in a narrow operating envelope. The heat recovery Dunham-Bush Water Cooled Screw Flooded Chiller, on the other hand, utilizes a positive displacement compressor which will not surge. This chiller is capable of unloading its compressors to their minimum capacity at all head conditions, both cooling and heat recovery, for greater design flexibility. The unit can be modified for Heat Reclaim use.

Lower Energy Consumption

The efficient unloading characteristics of the Dunham-Bush Water Cooled Screw Flooded Chiller compressor make it ideal for heat recovery duty. Heat recovery chillers must be selected to operate at many operating conditions, not just full load heating and full load cooling duties. Heat recovery chillers spend the majority of their time at lower loads, conditions at which centrifugal chillers must often be operating with energy inefficient hot gas bypass.

Free Cooling Not Free Heating

Even greater energy savings can be achieved when the Dunham-Bush Rotary Screw Water Cooled Heat Recovery Chillers are utilized to their maximum benefit. Typically heat recovery chillers had been thought to supply "free heat" while cooling a constant load within a building. The higher head conditions for heat recovery however cause the compressor to draw more power than for cooling only duty. The ideal way to utilize a heat recovery chiller would be to have it operate at only

the capacity required for the variable-heating load. This would enable the remainder of the base-cooling load to be handled by a separate chiller utilizing evaporator entering condensing water temperatures and greater energy efficiency. Unfortunately, centrifugal chillers do not have the ability to operate at lower percent loads enabling them to satisfy only the heating load required. As a result, centrifugal heat recovery chillers have typically been operating and satisfying the base cooling load and utilizing only a portion of the recoverable heat to satisfy the variable building-heating load. Dunham-Bush Rotary Screw Compressor characteristics, on the other hand, allow the heat recovery chiller to unload to very low load capacities at the high head conditions created in heat recovery operation. To utilize the Dunham-Bush Rotary Screw Heat Recovery Chillers to their fullest potential, the designer must change his way of thinking to providing chillers that are unloaded to provide only the heating load required and simultaneously supply a portion of free cooling to cover the base cooling load.

Controls

Units can also be provided with optional dual controls so they can control leaving chilled water or leaving condenser water. A dual bundle condenser is provided on a Heat Recovery Water Chiller which minimizes space requirements. Consult your local Dunham-Bush Sales Representative for additional details.

Head Pressure Control

Cooling tower control is increasingly becoming an overlooked subject, and it causes problems. The following is a general recommendation that is applicable to all standard packaged chillers.

Virtually all chiller manufacturers recommend that condenser water be controlled so that its temperature never goes below 60°F (even when the machine is off) and that its rate of change is not rapid. Rapid can be defined as not exceeding 2°F per minute. This is necessary because a chiller operates in a dynamic environment and is designed to maintain a precise leaving chilled water temperature under varying entering conditions. The additional dynamic of rapidly varying condenser water temperature subjects the machine to fluctuating pressure differentials across the evaporator and condenser. This varies the refrigerant flow and, therefore, the capacity. If this occurs faster than the machine can accommodate it, the head pressure or suction pressure will soon exceed their safety setpoints and the machine will shut down.

APPLICATION DATA

The necessary control can sometimes be attained via fan cycling if the tower is rated at the same capacity as the chiller and the machine will operate under heavy load and at design conditions. On multiple chiller jobs, a single tower is oversized relative to the chiller. On other jobs the tower/chiller might be oversized to the design load and the machine and tower frequently cycle under light load. Under these conditions, fan cycling might result in very rapid temperature swings, which creates a dynamic situation that occurs faster than the chiller control system can accommodate it. Thus, in this case, either variable speed fans or modulating valve control should be used to regain control of the condenser water. Either type of control provides precise modulating control of the condenser water rather than on-off step control. The control can be initiated either by a condenser water temperature sensor/controller or, even better, by direct control from the chiller's computer based upon the machine's head pressure.

It is further recommended that the condenser water pump be cycled by the chiller. This is to eliminate potentially very cold water from going through the condenser while the chiller is shut down. At the same time it is probable that relatively warmer chilled water is in the evaporator (an inversion). Refrigerant tends to migrate if there is a difference in pressures within the components of the chiller. It will seek the lowest pressure area of the packaged chiller which, in this case, would be the condenser. Starting of a chiller where the refrigerant has migrated to the condenser is not desirable. The presence of highly subcooled liquid refrigerant in the condenser will cause low suction pressures and possibly liquid slugging of the compressor. If the condenser water pump is off until the machine starts, the water in the condenser is at the machine room ambient, which is usually much closer to the evaporator water temperature. It should be noted that a flow switch in the condenser water is not required.

Our unit wiring diagrams show the condenser water pump interlocked with our chiller and controlled to come on only when a compressor is energized. We also have an optional analog output on the controller that can be used to control the tower directly from the head pressure of the machine. The digital outputs can be used for three-point floating (or tri-state) control and the analog can be used to drive a 0 - 10 vdc actuator.

Thus, even though there has been a trend toward fan cycling control of cooling towers, it is not a device that is suitable to every installation. We recommend that the

designer carefully evaluate the system to determine if a more precise method of control is indicated. If there is any doubt, the more precise control is required. We also recommend that the condenser water pump interlock in the chiller control panel be used to enable and disable the condenser water pumps.

Dunham-Bush Water Cooled Chillers have as standard a control feature called EPCAS (Evaporator Pressure Control at Start) which will allow for an inverted start. This occurs when the chilled water loop in a building is at a higher temperature than the condenser/tower loop. This occurs in many buildings after a weekend shut down. The chilled water loop can be as high as 90°F and the condenser/tower loop as low as 60°F. With the EPCAS feature, the valve feeding the evaporator will be throttled to create a pressure differential to help load the compressor.

Ice Storage

With a positive displacement rotary screw compressor, the Dunham-Bush water chiller can easily cool low temperature glycol down to 22°F with entering condenser water of 85°F. The same chiller can also produce warmer (40° to 45°F) leaving glycol for those building systems designed for only peak shaving. This can be accomplished by an external signal to the unit controller. No matter what your ice storage needs, the Dunham-Bush Water Cooled Screw Flooded Chiller can handle it better than any other chiller. The use of multiple compressors minimizes the amount of horsepower used at any condition high temperature glycol for direct cooling in coils or low temperature glycol for producing ice at off-peak power rate times.

Multiple Unit Control

One of the most perplexing problems to system designers is control of multiple chillers on the same water loop. The first decision is whether to put the chillers in parallel or series on the chilled waterside. If lower pumping cost is paramount, then putting chillers in series is often preferable. If primary/secondary pumping is utilized with normal 10°F range, then putting chillers in parallel is normally used. In either case, the Dunham-Bush controller can control up to six chillers. This eliminates the need for external control interface which often becomes difficult. If more than five chillers need to be controlled, an Equipment Management Center can be supplied for controlling/ monitoring up to ten units.

EQUIPMENT

Standard Equipment And Factory Installed Options

Dunham-Bush Water Cooled Screw Flooded Chillers, like many other Dunham-Bush products, distinguish themselves by offering as standard many features that other manufacturers provide only as costly options.

Some of the Standard Features of these chillers which provide for efficiency and reliability are:

- ✿ Addition of service valve in suction and vapor injection lines on each compressor allow replacement of one compressor while others are running and also allow refrigerant storage in the evaporator via a service compressor.
- ✿ Unit mounted and wired reduced inrush starting system.
- ✿ Factory mounted and wired control power transformer.
- ✿ Single point electrical power connection.
- ✿ Undervoltage phase failure relay.
- ✿ Controller monitoring of evaporator leaving water temperature.
- ✿ Controller monitoring of suction & discharge pressures.
- ✿ Controller monitoring of power supply volts.
- ✿ Controller monitoring of single phase amps for each compressor.
- ✿ Controller monitoring of each compressor, number of starts (cycles) and elapsed time for both a by hour period or total time and cycles.
- ✿ Units shipped completely factory tested, charged and adjusted for ease of installation and minimal

field start-up adjustments.

- ✿ Chilled water reset from control panel or external building automation system.
- ✿ High oil temp, low oil level, freeze, low suction pressure, high discharge pressure, and solid state overload protection are all featured.
- ✿ Unit mounted circuit breaker for each compressor on two and three compressor units.
- ✿ Discharge check valves on multiple compressor units allow refrigerant charge to be stored in the condenser for service to compressor or evaporator.

Additional Features offered by Dunham-Bush as Factory Installed Options include:

- ✿ Insulation of all low temperature surfaces.
- ✿ Hot gas bypass for very low load situations.
- ✿ Controller monitoring of return chilled water and entering and leaving condenser water in addition to the standard leaving chilled water temperature.
- ✿ Personal computer with communication software installed to enable the remote monitoring of all functions and inputs to the controller.
- ✿ Dual bundle heat reclaim condensers are available for special applications.
- ✿ Control of up to five packages via a master slave arrangement requiring only two shielded cables between units. Up to ten packages can be controlled via an Equipment Management Center.
- ✿ Unit mounted disconnect switch 400 to 575 volts applications.
- ✿ Flanged semi-hermetic compressor.
- ✿ Discharge service valve for MSC 226 series compressor.

GUIDE SPECIFICATIONS

1. The contractor shall in accordance with the plans, furnish and install _____ Dunham-Bush _____ packaged liquid chiller(s). The unit(s) shall be completely factory packaged including rotary screw compressor(s), evaporator, condenser, and control panel. The packaged chiller shall be factory assembled, charged and tested with a full operating refrigerant and oil charge. The refrigerant type shall be R134a.
2. Capacity of each chiller shall be not less than _____ refrigerant tons (kW output) cooling at _____ GPM (liters/min.) of water from _____ °F(°C) to _____ °F(°C). Power input requirements for the unit(s), incorporating all appurtenances necessary for unit operation, including but not limited to the control accessories and pumps, if required, shall not exceed _____ kW input at design conditions. The unit shall be able to unload to _____% of cooling (refrigeration) capacity when operating with leaving chilled water and entering condenser water at design temperatures. The unit shall be capable of continuous operation at this point, with stable compressor operation, without the use of hot gas bypass.
3. Heat transfer surfaces shall be selected to reflect the incorporation of a fouling factor of .00025 hr.sq.ft. °F/BTU (0.000044m².°C/W) for the water condenser and 0.0001 for evaporator. Water pressure drop at design conditions shall not exceed _____ feet of water through the condenser, and _____ feet of water through the evaporator.
4. The packaged chiller shall be furnished with single-stage direct connected positive displacement rotary screw compressor(s) as required, driven by a 3500 RPM (2900 RPM-50Hz) motor. Each compressor shall include integral oil separation system, oil sump and oil filter. The oil differential pressure shall be controlled during operation to maintain proper oil lubrication throughout the lubrication system. An electric oil heater shall be supplied with each compressor to maintain oil temperature during shutdown period. Each compressor shall have a suction check valve, suction filter, (suction service valve) (and a discharge check valve). Compressor capacity control shall be obtained by an electrically initiated, hydraulically actuated slide valve within each compressor. (Provide isolation valves on all connections to compressor to allow condenser to be used as a pump down receiver).

GUIDE SPECIFICATIONS

5. Evaporator and condenser vessels shall all be cleanable shell and tube type with integral finned copper water tubes mechanically expanded into heavy fixed steel tube sheets. They are to be available in one, two or three pass design as required on the drawings with Victaulic connections. The shell side of the evaporator and condensers shall have pressure relief valve with provision for refrigerant venting. Evaporators and condensers shall be designed, constructed in accordance with the ASME Code for Unfired Pressure Vessels. The condenser shall be sized for full pump down capacity. The flooded evaporator shall have a built in distributor for feeding refrigerant evenly under the tube bundle to produce a uniform boiling action and baffle plates shall be provided to ensure vapor separation. Water heads are to be removable for tube cleaning. Vent and drain plugs are to be provided in each head. (All low temperature surfaces shall be factory insulated.) (Provide a dual bundle on condenser for heat reclaim.)
6. The flooded evaporator shall be fitted with an oil recovery system. The oil recovery system will insure that the evaporator is operating at peak efficiency at all times and provide optimal energy efficiency during extended periods of part load. Units without oil recovery systems mounted on the evaporator will not be acceptable.
7. To maximize energy efficiency, the packaged chiller shall be equipped with a economizer and modulating refrigerant expansion devices. Refrigerant vapor from the economizer shall be fed back into an intermediate compressor stage, reducing the enthalpy of the refrigerant and increasing the net refrigeration effect of the evaporator.
8. The packaged chiller shall be furnished with a modulating refrigerant control system to optimize efficiency and compressor protection. This refrigerant control system will reduce the flow of efficiency robbing refrigerant vapor in the condenser from entering the evaporator at reduced load by directly modulating a motorized refrigerant valve in the liquid line entering the evaporator. In addition, the refrigerant control system shall measure the level of liquid refrigerant in the flooded evaporator and restrict refrigerant flow entering the evaporator upon a rise in the level, protecting the compressor from slugging liquid refrigerant. Fixed orifice control systems will not be acceptable. (Hot gas bypass shall be factory installed for operation down to approximately 10% of full load.)
9. The packaged chiller shall be equipped with controller control. The control shall provide for compressor loading based on leaving chilled water temperature. It shall provide for high and low refrigerant pressure protection, low oil level protection, evaporator water freeze protection, sensor error protection, and motor load control (demand limiter) based on amp draw. Anti-recycle protection shall also be provided. The computer shall have a simple keyboard accessed input system and be complete with 320x240 pixel, 256 color display. Input shall be accomplished through

simple menu driven display screens, with on-line help available by pressing a help button at anytime during operation. The controller shall continuously monitor evaporator leaving water temperature; evaporator and condenser pressure; compressor amp draw; and refrigerant. The computer shall be complete with all hardware and software necessary to enable remote monitoring of all data through the addition of only a simple, phone modem and terminal. The controller shall be completed with an RS232 "local" communications port and an RS485 long distance differential communications port. The controller shall also accept a remote start and stop signal, 0 to 5VDC chilled water temperature reset signal and (0 to 5VDC compressor current limit reset signal). Terminal or PC with communication software installed to enable remote monitoring.

10. The electrical control panel shall be wired to permit fully automatic operation during - initial start-up, normal operation, and shutdown conditions. The control system shall contain the following control and safety devices:

MANUAL CONTROLS

- ✿ Control circuit stop and start switches
- ✿ Compressor enable switch

SAFETY CONTROLS

- ✿ Solid state compressor motor starter overloads (3 phase)
- ✿ Low oil level optical sensor
- ✿ High condenser pressure
- ✿ Low evaporator pressure
- ✿ Freeze protection
- ✿ Chilled water flow loss
- ✿ Under voltage phase failure relay

AUTOMATIC CONTROLS

- ✿ Compressor motor increment contactors
- ✿ Increment start timer
- ✿ Anti-recycle timer
- ✿ Oil sump heater interlock relays

REFRIGERANT CONTROLS

- ✿ Motorized refrigerant flow control
- ✿ Liquid refrigerant level sensor for evaporator
- ✿ Compressor load and unload solenoid valves

INDICATOR LIGHTS

- ✿ Power on
- ✿ Compressor high oil temperature
- ✿ Compressor motor overload
- ✿ System common alarm

11. The control system shall be provided with an anti-recycle device. The control shall limit compressor starting to a minimum of 15 minutes between starts.
12. The packaged chiller shall be furnished with unit mounted reduced inrush starting system for each compressor. The starters shall be factory mounted and wired, with individual circuit breakers on multiple compressor units. The unit shall be wired so that the only field electrical connection to the packaged chiller shall be to a single three-phase power terminal.

Optional items in ()